

Assembly Instructions

Wheelchair Wood Octagonal Table

WOCT002-01-280422



PicnicTable

Superior Picnic Tables Made In The UK

Contents:

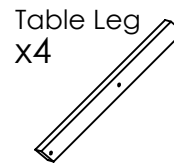
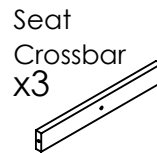
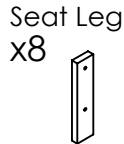
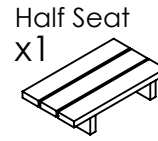
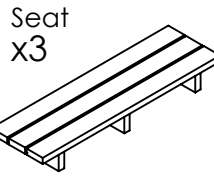
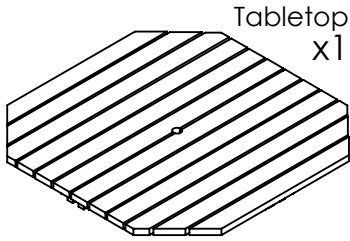

Fixings	QTY
M10x120 Bolt	4
M10x100 Bolt	8
M10x80mm Bolt	12
M10x50mm Bolt	12
M10 Nut	36
M10 Washer	72

Tools Required: 17mm Spanner

Step 1: Assemble the seat frames using 100mm, 80mm and 50mm bolts, bolting the seat legs together with the table crossbar, and into the seat. Bolt the table leg to the table crossbar then bolt into the seat undercarriage. Repeat x3.

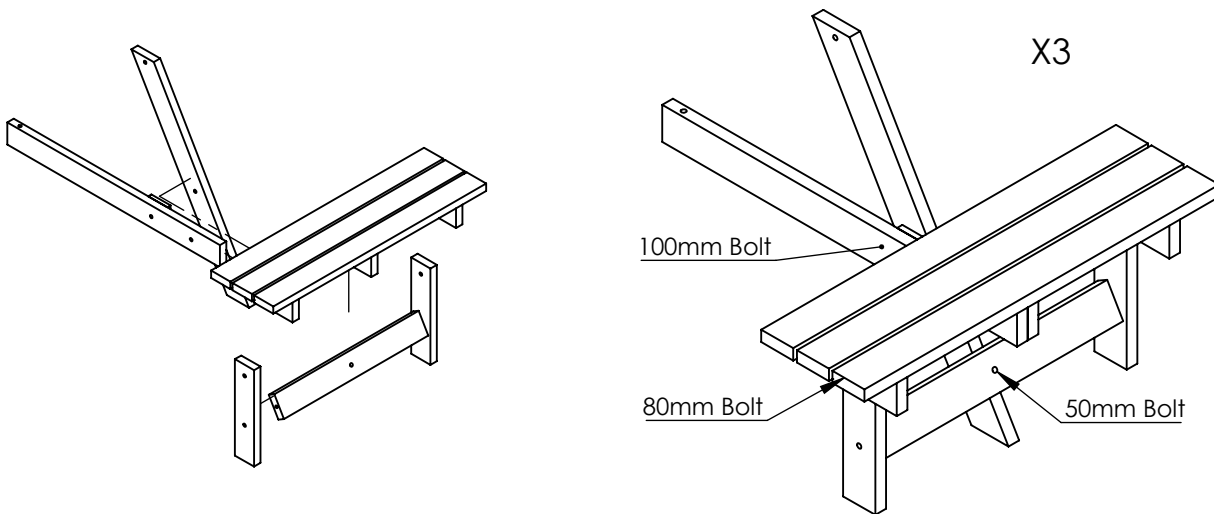

Step 2: Assemble the half size wheelchair seat using same method as previous seats.

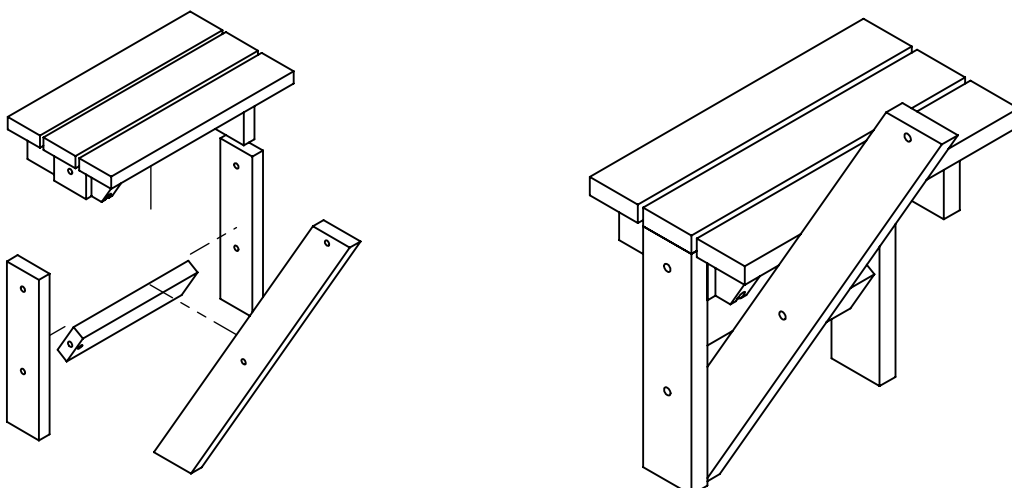

Assembly Instructions

Wheelchair Wood Octagonal Table

WOCT002-01-280422



PicnicTable

Superior Picnic Tables Made In The UK

Step 3: Move to final location and bolt the assembled seats into the undercarriage block as shown below, using M10x100mm bolts.

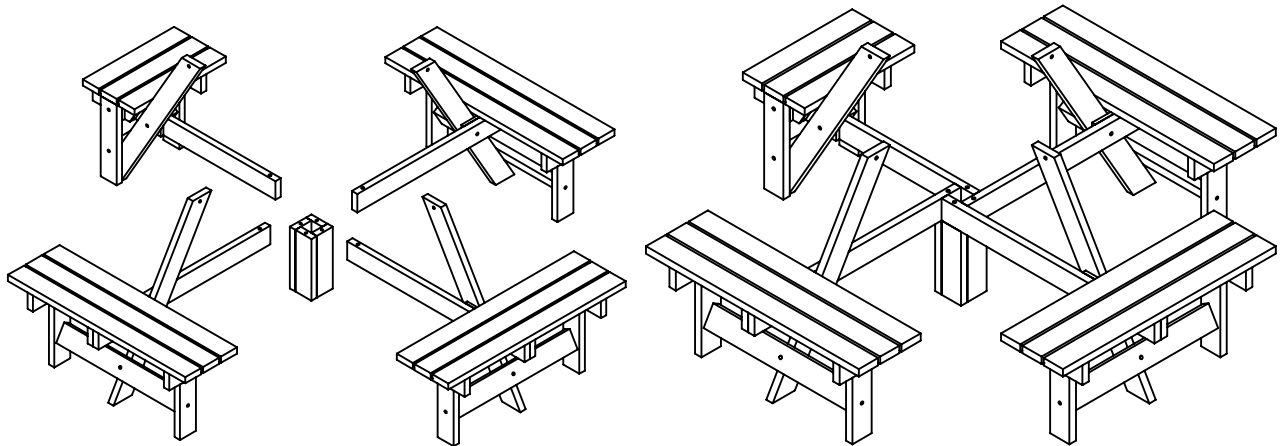

Step 4: Move the tabletop into position and bolt through the legs using x4 M10x120 Bolts.

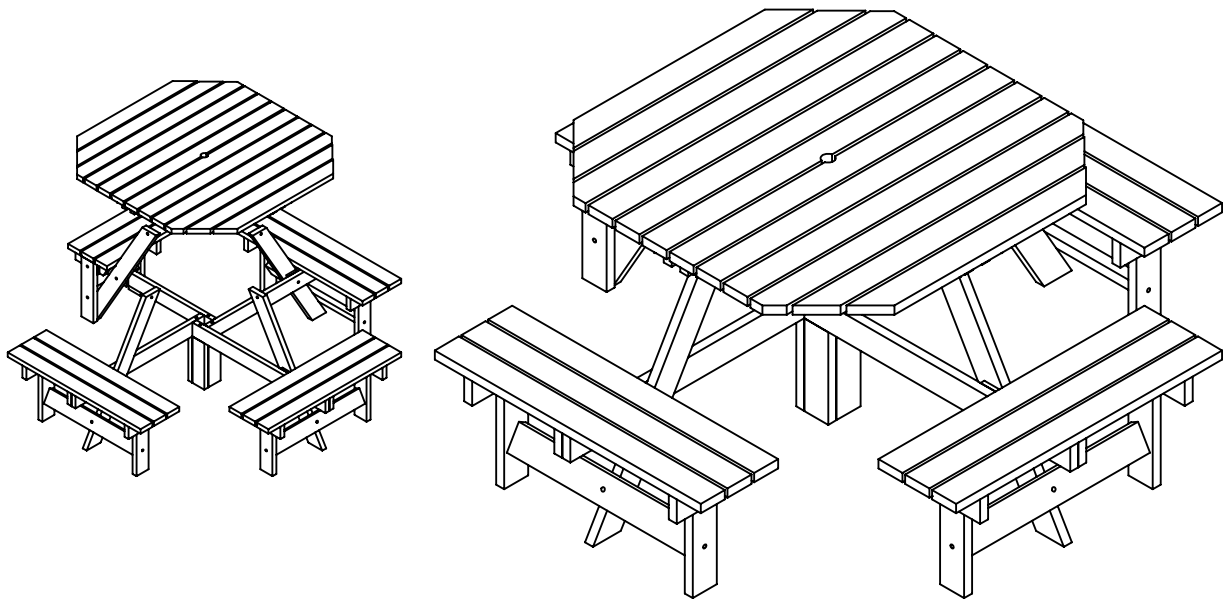

Maintenance:

15 years guarantee.

If damaged, repair and treatment is required.

Can be cleaned with soapy water.

Dependent on environment, more frequent treatment may be required.

Pressure treated tanalised timber (Class 4, BS EN 335-1 for direct contact with soil and fresh water).

Contact: Tel - 08081751903 **Email** - sales@picnictable.co.uk
Web - picnictable.co.uk

THANK YOU FOR YOUR BUSINESS