

# Wheelchair Access Picnic Table



## Assembly Guide

**NBB**   
Recycled  
Furniture

**NBB**   
Outdoor  
Shelters

**NBB**   
Premises  
& Matting

**NBB**   
School  
Shelters

NOTES:

# Parts and Fittings

## Table Top

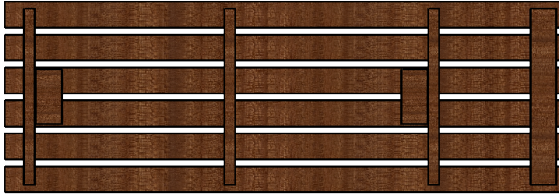

x1

Two People required  
for Safe Assembly

## Bench Seat

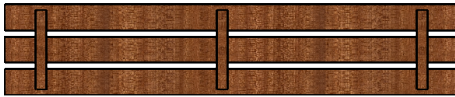

x2

## Legs

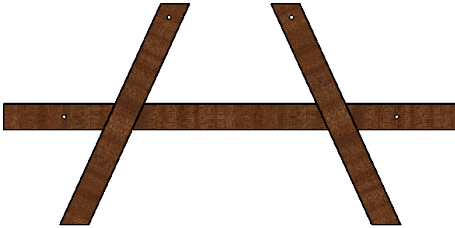

x3

## Fittings



## Tools supplied



17mm Spanner

6mm Allenkey

**Step 1** Place Table top upside down on any soft, flat surface.

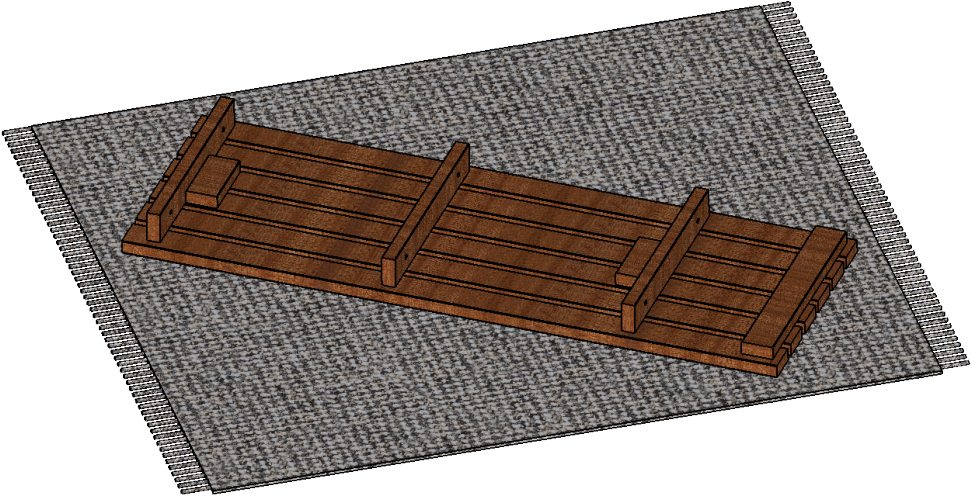

**Step 2** Attach the Legs and tighten nuts and bolts with Spanner and Allen Key.

Legs

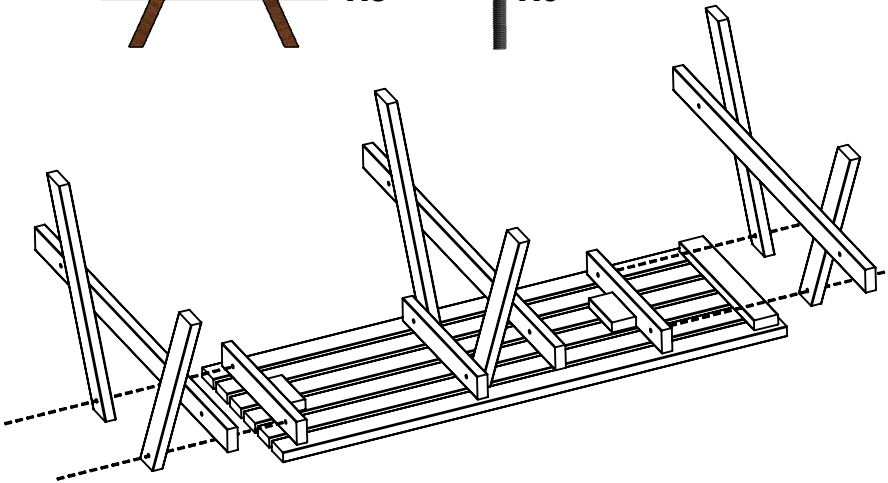
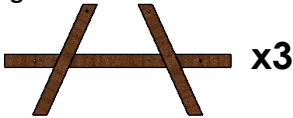

**Step 3** Attach Bench seats. One person should hold it in Position. Other person tighten nuts and bolts. Repeat for other side. Ensure all nuts and bolts are fully tightened at this step.

Bench seats

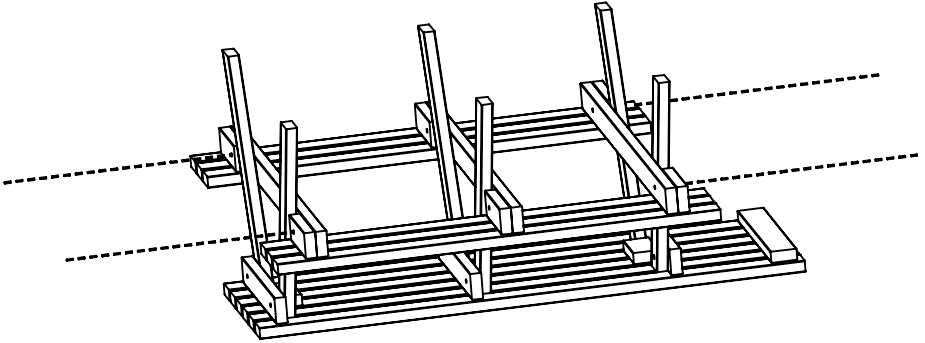
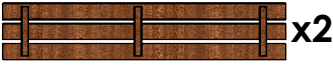

**Step 4** Flip table over using two people.

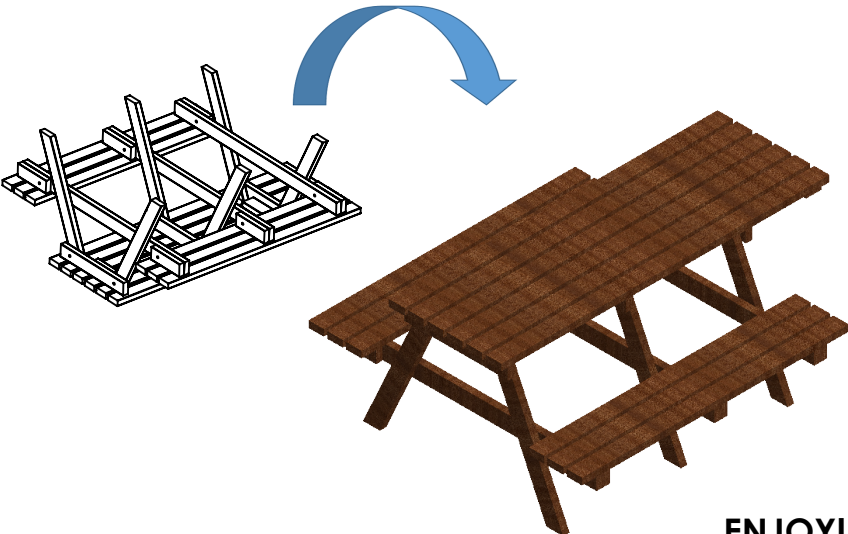

**ENJOY!**

NOTES:

NOTES:

# THANK YOU FOR PURCHASING THIS PRODUCT

## Contact Details:

Email : [sales@recycledfurniture.co.uk](mailto:sales@recycledfurniture.co.uk)

Web : [www.recycledfurniture.co.uk](http://www.recycledfurniture.co.uk)

Tel : 0800 1777 052

NBB Recycled Furniture, Unit 5, 145  
Sterte Road, Poole, Dorset BH15 2AF