

Wheelchair Access Picnic Table

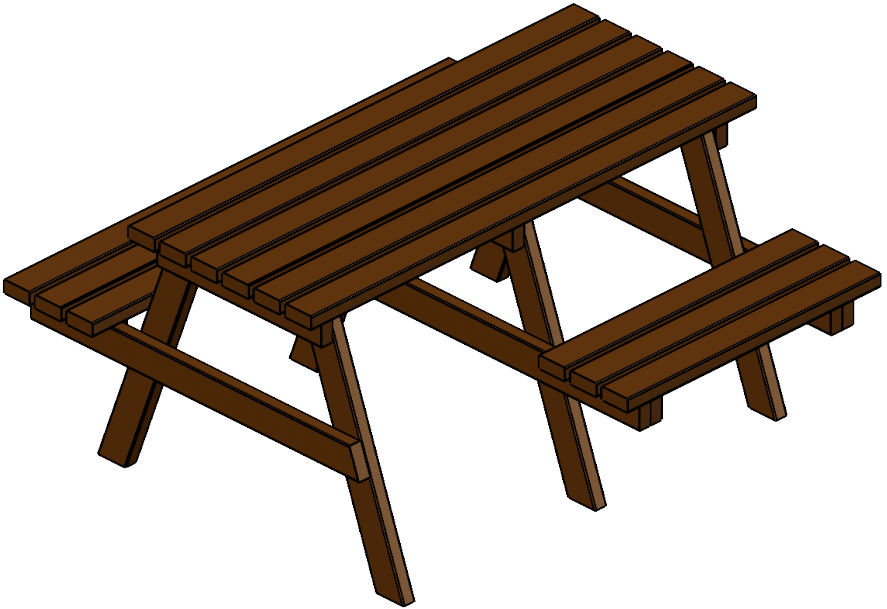

Assembly Guide

NBB 
**Recycled
Furniture**

NBB 
**Outdoor
Shelters**





NBB 
**Premises
& Matting**

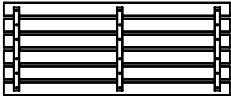

NBB 
**School
Shelters**

Notes:

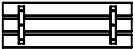
Parts and Fittings

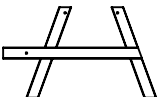
Two People required
for safe assembly

Table Top 	x1
Bench Seat 	x1
Wheelchair Bench Seat 	x1
A-Frame Legs 	x2
Wheelchair A-Frame Legs 	x1

Fittings			
	x11		x11
90mm			x22

Tools supplied		
	17mm Spanner	x1
	6mm Allen Key	x1

Step 1

Place table top on a soft, flat surface.

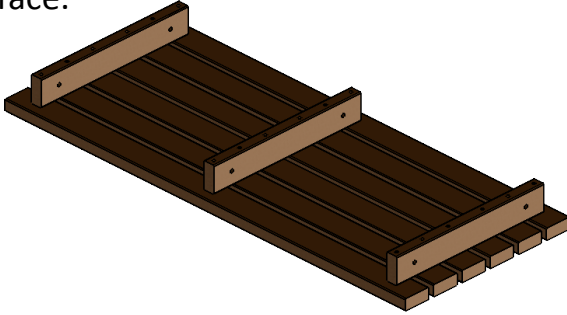

Do not over-tighten bolts during assembly as small adjustments will help parts fit.

Step 2

Use 90mm bolts to secure legs as shown below.

Wheelchair A-Frame

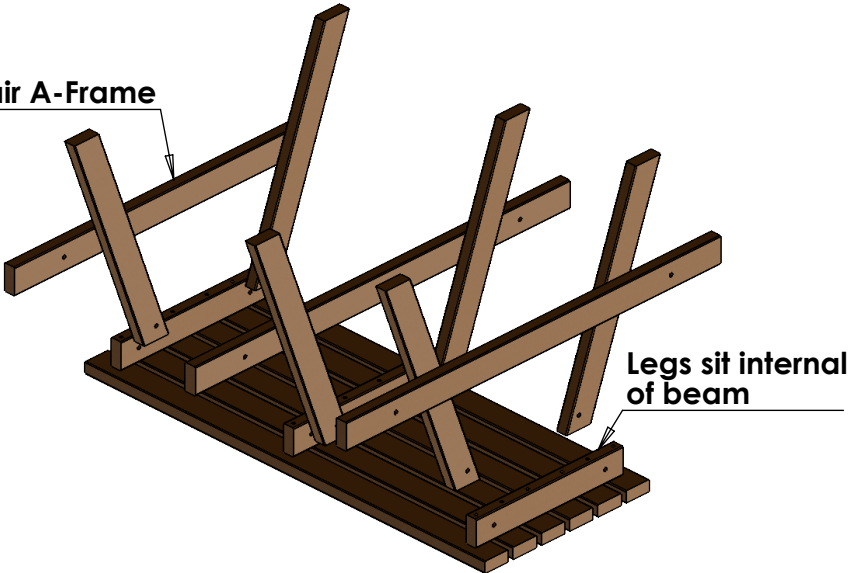

Step 3

Flip table using two people.

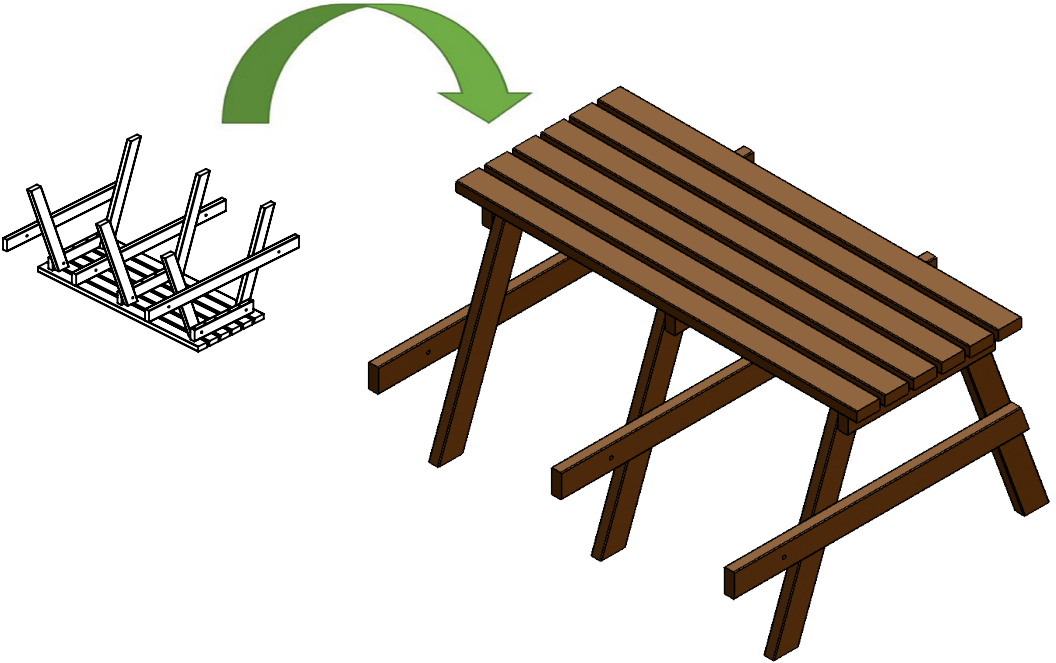

Step 4

Secure seats to legs as seen below using 90mm bolts.

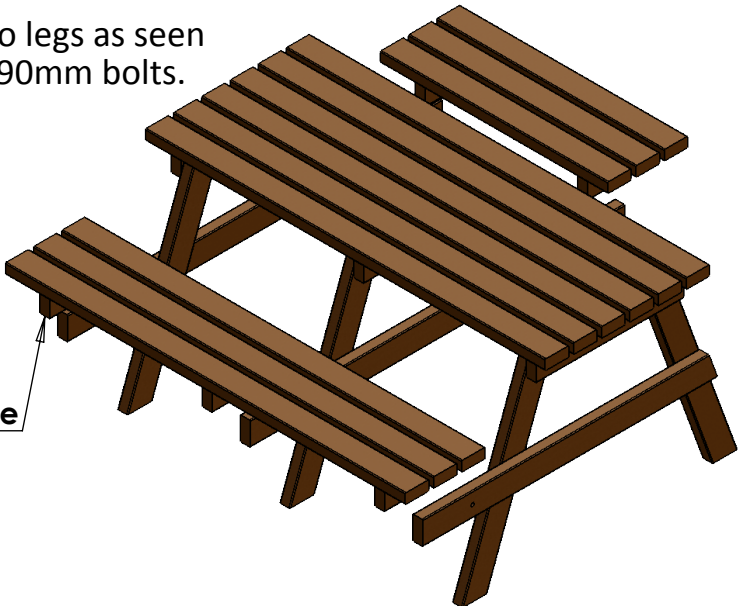

Seat braces
internal of A-Frame

Notes:

Notes:

THANK YOU FOR PURCHASING THIS PRODUCT

CONTACT DETAILS:

Email : sales@recycledfurniture.co.uk

Web : www.recycledfurniture.co.uk

Tel : 0800 1777 052

NBB Recycled Furniture, Unit 5, 145 Sterte Road, Poole, Dorset BH15 2AF

All Parts and Fixings checked by:	
Print Name:	Signature