

# Wheelchair Octagonal / Round Table Instructions



## Assembly Guide

**NBB**   
**Recycled  
Furniture**



**NBB**   
**Outdoor  
Shelters**

**NBB**   
**Premises  
& Matting**

**NBB**   
**School  
Shelters**

# Parts and Fittings

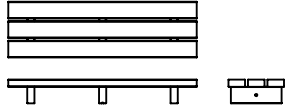
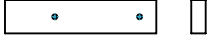
**Two People required  
for safe assembly**

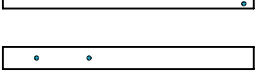
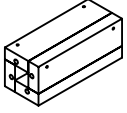
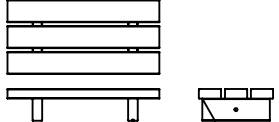
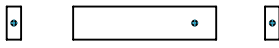
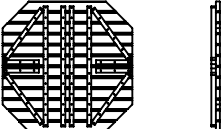
ITEM NO.	PART NAME	DRG NO:	IMAGE	QTY.
1	Octagon - Round Seat - 995x294 - OR	OR-001-01		3
2	UC2 - 400x88x38 - OR	OR-021-01		8
3	UC3 - 643X88X38 - OR	OR-022-01		3
4	UC5 - 900x88x38 - OR	OR-025-03		4
5	UC1 - 995x88x38 - OR	OR-020-01		4
6	UC - 312x88x38 Block -OR	OR-024-02		1
7	Wheelchair Octagonal Seat Assembly	WOR-002-01		1
8	UC3 - 378.5x88x38 - WOR	WOR-003-01		1
9	Octagonal Table Assembly - OR	OR-005-07		1

## Fixings

FIXING	QTY.
M10 X 130	5
M10 X 110	4
M10 X 90	16
M10 X 60	12
M10 WASHER	66
M10 NUT	24

Note: List shows kit contents, some fasteners may be spare depending on the version of product purchased.

### Tools Required



17mm Spanner

**x1**

6mm Allen Key

**x1**

# Step 1

Bolt leg UC5 to UC1 using 90mm bolts supplied, repeat for all other legs.

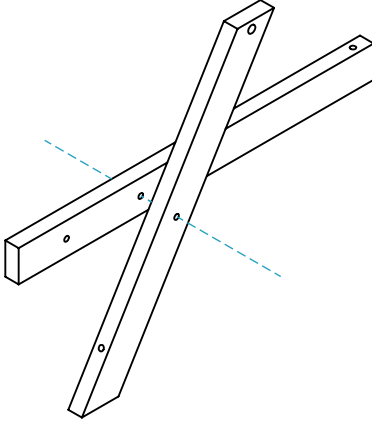

**Do not over-tighten bolts during assembly as small adjustments will help parts fit.**

# Step 2

Assemble seats as below using (2x) 90mm & (2x) 60mm bolts supplied.

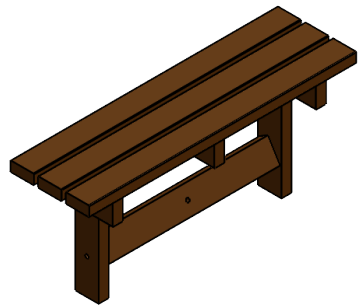
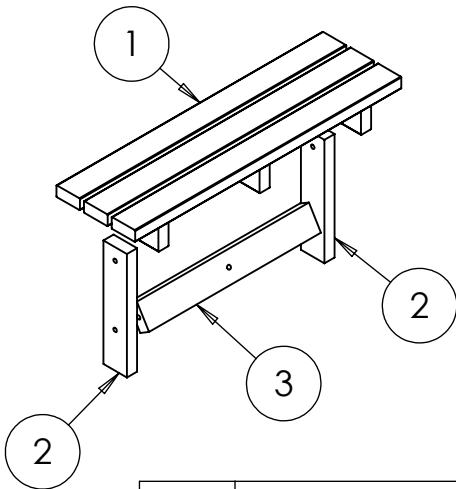

ITEM NO.	PART NAME	DRG NUMBER	Step 2/QTY.
1	Octagon - Round Seat - 995x294 - OR	OR-001-01	1
2	UC2 - 400x88x38 - OR	OR-021-01	2
3	UC3 - 643X88X38 - OR	OR-022-01	1

# Step 3

Assemble half seat as below, using (1x) 90mm bolt & (2x) 60mm bolts.

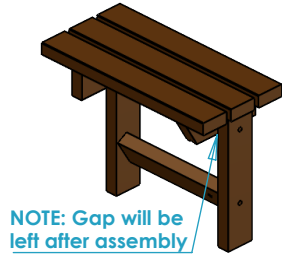
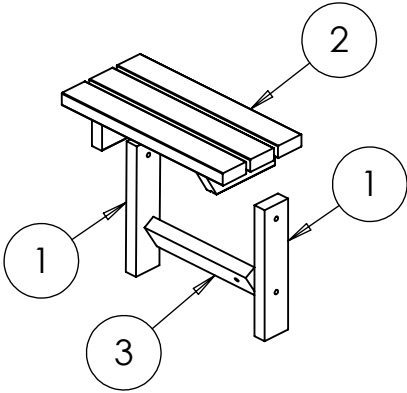

ITEM NO.	PART NAME	DRG NUMBER	Step 3/QTY.
1	UC2 - 400x88x38 - OR	OR-021-01	2
2	Wheelchair Octagonal Seat Assembly	WOR-002-01	1
3	UC3 - 378.5x88x38 - WOR	WOR-003-01	1

# Step 4

## STEP 1 & 2

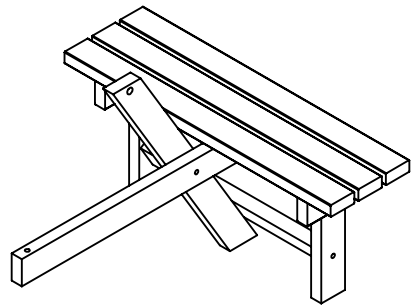
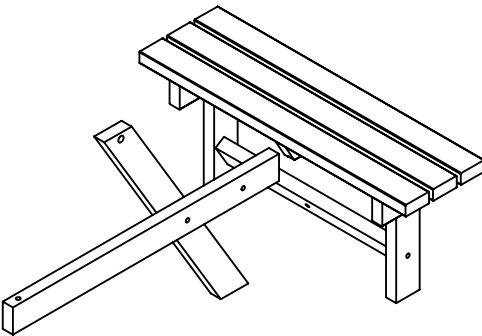

Bolt step 1 & 2 assemblies together using (1x) 90mm & (1x) 60mm bolts per seat.

# Step 5

Bolt step 1 & 3 assemblies together using (1x) 60mm & (1x) 130mm bolts.

## STEP 1 & 3

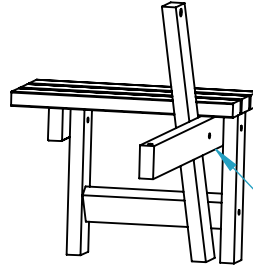
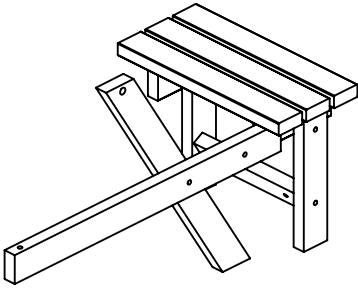

UC1 will slot between the seat brace and UC2.

---

# Step 6

Secure seat assemblies to the block using (4x) 110mm bolts.

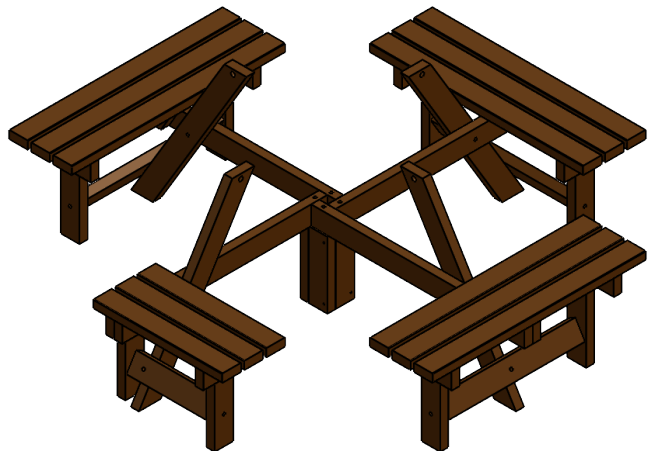
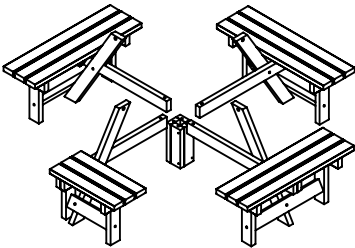

## Step 7

Bolt the table top to the 4 legs centrally, using (4x) 130mm bolts.

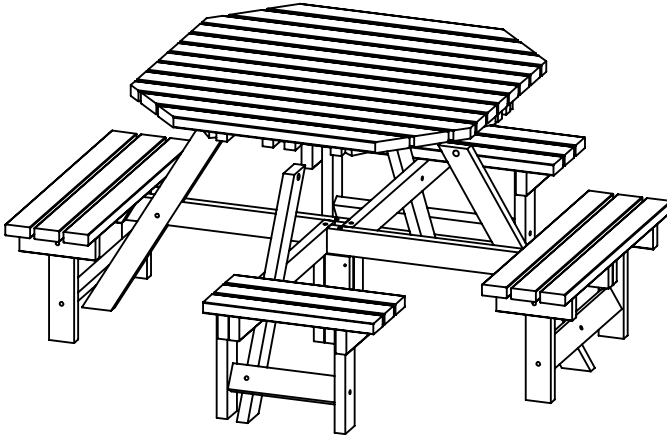

**NOTE:** When locating bolts legs may require adjustment

**Finally Tighten all bolts fully before use.**

**Notes:**

# THANK YOU FOR PURCHASING THIS PRODUCT

**CONTACT DETAILS:**

Email : [sales@recycledfurniture.co.uk](mailto:sales@recycledfurniture.co.uk)

Web : [www.recycledfurniture.co.uk](http://www.recycledfurniture.co.uk)

Tel : 0800 1777 052

NBB Recycled Furniture, Unit 5, 145 Sterte Road, Poole, Dorset BH15 2AF

<b>All Parts and Fixings checked by:</b>	
Print Name:	Signature