



**FAST  
FIX**

CLASS II APPARATUS



EN50291-1:2018

ASSOCIATE STANDARD  
BS 5839-6:2019 GRADE D2

## MODEL: HSSA/CO/FF

**220 ~ 240V AC OPERATED CARBON MONOXIDE ALARM WITH 9V BATTERY BACKUP**

### MAIN FEATURES:

- Replaceable 9V Battery Backup
- Power & Alarm Indicator LED
- Low Battery Warning
- Loud 85db alarm signal
- Supplied with fixing kit
- Pre-warning fault signal
- Kitemark Approved: EN50291-1:2018
- Compatible with Control Unit HSSA/CU

This instruction leaflet contains important information on the correct installation and operation of your alarm. Read this leaflet fully before attempting installation and retain for future reference.

### SPECIFICATION

Power Source:	220-240 Vac~ 50-60Hz with 9V battery Back-up (battery included)
Battery Back-up Life:	In the event of a break in the mains supply the battery will give detector operation for 1 month minimum
Operation Current:	<35 mA operation (In Alarm)
Temperature Ambient:	-10°C - 40°C
Ambient Humidity:	10%-90%
Max. Wire interconnection:	20 units over 150m
Sensor Type:	Electrochemical
Alarm Sound Level:	85 Decibels at 3 metres
Approval:	Certified to EN50291-1:2018
Kitemark:	KM 792791

### PRODUCT DESCRIPTION

HSSA/CO/FF is a multiple station carbon monoxide alarm and can be connected to other alarms of the same make and type. This interconnect feature allows up to 20 units to be connected together over 150 metres maximum, using the single white wire, and thus allowing all alarms to sound when any one is activated.

**Note:** This alarm cannot be connected to any other device such as a fire alarm panel.

### LOCATING THE CO ALARM

Ideally, a CO alarm should be installed in every room containing a fuel burning appliance. Additional apparatus may be installed to ensure that adequate warning is given for occupants in other rooms, by locating apparatus in remote rooms in which the occupant spend considerable time whilst awake and from which they may not be able hear an alarm from apparatus in another part of the premises, and every sleeping room.

- An apparatus should be located in a room containing a flueless or open-flued appliance.
- If there is an appliance in a room where people spend most time, an apparatus should be placed in that room.
- If there is an appliance in a room where people sleep, an apparatus should be placed in that room.
- In a bedsit, the apparatus should be placed as far from the cooking appliances as possible but near to where the person sleeps.
- If the appliance is in a room not normally used, such as boiler room, the apparatus should be placed just outside the room so that the alarm will be heard more easily.

**CAUTION** - This alarm will only indicate the presence of carbon monoxide gas at the sensor. Carbon Monoxide gas may be present in other areas. This carbon monoxide alarm is designed to detect carbon monoxide gas from ANY source of combustion. It is NOT designed to detect smoke, fire or any other gas.

### POSITIONING THE CO ALARM

Carbon Monoxide has a similar density to warm air and can be found various locations. Apparatus should be located in the same room as a solid-burning appliance:

- If the apparatus is located on a wall, it should be located at a height greater than the height of any door or window but at least 150 mm from the ceiling. If the apparatus is mounted on a ceiling, it should be at least 300 mm from any wall.
- The apparatus should be at a horizontal distance of between 1m and 3M from the potential source.

- If there is partition in a room, the apparatus should be located on the same side of the partition as the potential source.
- In rooms with sloped ceilings, the apparatus should be located at the highest side of the slope.

**Apparatus located in sleeping rooms and in rooms remote from a fuel burning appliance:**

- The apparatus should be located relatively close to the breathing zone of the occupants.

**FIGURE 1 - POSITION OF ALARM IN A ROOM WITH FUEL BURNING APPLIANCE**

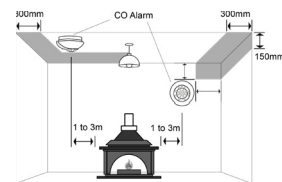

**FIGURE 2 - POSITION OF ALARM WITH NO APPLIANCE IN ROOM**

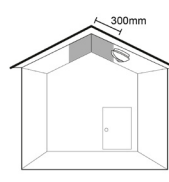

### AREAS TO BE AVOIDED:

- Situations where the temperature may fall below -10°C or rise above 40°C for extended periods
- Humid areas such as BATHROOMS, SHOWER ROOMS where the relative humidity may exceed 90% as vapour will cause false alarms.
- Next to a door or window or in the path of air discharged from a FURNACE / AIR CONDITIONING VENT or CEILING FAN.
- Where the air flow to the apparatus would be obstructed by CURTAINS or FURNITURE.
- In VERY DUSTY OR DIRTY environments such as workshops.
- Locate unit at least 1.5m and route wiring at least 1m away from FLUORESCENT LIGHT FITTINGS as electrical "noise" and/or flickering may affect the unit. Do not wire into the same circuit as fluorescent lights or dimmers.
- Do not locate in INSECT INFESTED AREAS. Insects and contamination on the alarm sensor can increase its response time.
- Directly above a SINK or COOKER.
- In or below a CUPBOARD

**The following conditions can result in transient CO situations in the home:**

- Excessive spillage or reverse venting of fuel burning appliances caused by:
  1. Outdoor ambient conditions such as wind direction and/or velocity, including high gusts of wind; heavy air in the vent pipes (cold/humid air with extended periods between cycles).
  2. Negative pressure differential resulting from the use of exhaust fans.
  3. Simultaneous operation of several fuel burning appliances competing for limited internal air.
  4. Vent pipe connection vibrating loose from clothes dryers, furnaces, or water heaters.
  5. Obstructions in or unconventional vent pipe designs which amplify the above situations.
- Extended operation of unvented fuel burning devices (range, oven, fireplace, etc.).
- Temperature inversions which can trap exhaust gases near the ground.
- Car idling in an open or closed attached garage, or near a home.

**WARNING - This carbon monoxide alarm is designed for indoor use only. Do not expose to rain or moisture. It will not protect against the risk of carbon monoxide poisoning when the battery has drained. Do not open or tamper with the alarm as this could cause malfunction.**

### INSTALLING THE CO ALARM

**WARNING** – This alarm is mains powered and requires wiring by a qualified electrician in accordance with the current IET Wiring Regulations (BS7671).

### BATTERY REPLACEMENT

If the CO Alarm emits a short 'beep' once a minute the battery is at the end of its life and should be replaced immediately. This low voltage warning will be given for at least 30 days.

Always TURN OFF the A.C. supply to the apparatus before replacing the battery.

Each time after replacing with a new battery, the user has to test the alarm by pressing the test button to ensure the detector is working correctly

- Unlock the apparatus unit from the base by pushing up the temporary latch with a screw driver
- Remove the old battery from the compartment.
- Insert a new, healthy 9V battery. NOTE POLARITY OF CONNECTIONS.
- Using the Push to Test button to test the CO Alarm. See "TESTING YOUR CO ALARM"
- Reattach the CO alarm to the mounting base

**WARNING: DANGER OF EXPLOSION IF BATTERY IS INCORRECTLY REPLACED. THE USE OF BATTERIES OTHER THAN THOSE RECOMMENDED ON THE BACK OF THE CO ALARM MAY BE DETRIMENTAL TO ITS OPERATION**

### Assemble alarm unit to the mounting base

Before wiring to the mains, assemble the alarm unit onto the mounting base by sliding it in according to the direction of the arrows. Test the correct operation of the alarm (operating from the battery only) by pressing the test button on the front of the alarm. The unit should emit a loud pulsating alarm.

The circuit used to power the alarm must be a dedicated permanent supply that cannot be switched off accidentally by the normal user. Before installing ensure the electrical supply is isolated.

**WARNING: To prevent injury, this alarm must be securely attached to the ceiling/wall in accordance with the installation instructions.**

The alarm will function correctly either as a stand-alone alarm or interconnected. All interconnected alarms must be supplied from a single power circuit. A common neutral must be used for the interconnect to function.

**WARNING: Do not connect the interconnect wire to Live, Neutral or Earth.**

Disconnect the AC main power from the circuit that is going to be used. Having established the mounting location install a junction box suitable for locating the termination point. Ensure that there is no other electrical wiring or pipe work in the area adjacent to the mounting surface.

### To fix the mounting base into position

- Find and remove the key lock from the Mounting Base. Keep this for replacing after install. See **Figure 5**

- Use a Screw driver to remove the Wiring Cover. See **Figure 6**.
- Connect the wires to the correct terminals (on the mounting base) to incoming supply. If alarms are to be interconnected, link out the interconnection terminals. Ensure the screws are fully tightened.

See **Figure 4 or 5**

- Fix mounting base in position.
- **NEVER USE EARTH AS INTERCONNECT.**
- Insert the Lock Key into the Lock Hole at the side of mounting base. See **Figure 7**
- Restore the AC supply
- Test the correct operation of the detector by holding the test button for 2 seconds (working off battery power only). The detector should emit a pulsating chirp.
- To lock the alarm unit onto the Mounting Base, insert the Lock Key into the key hole. See **Figure 8**.

### To remove the alarm unit from the mounting base:

- Use a screwdriver to pick out the lock key from the key hole. The Key hole is located at the side of Mounting Base. See **Figure 8**.
- Use a screwdriver to release the alarm unit from the mounting base by pushing up the security latch with a screw driver. See **Figure 8**
- Slide the alarm unit out from the mounting base.

**FIGURE 4 – WIRING AND INTERCONNECT**

20 alarms maximum  
150 metres maximum between first and last interconnected alarm unit

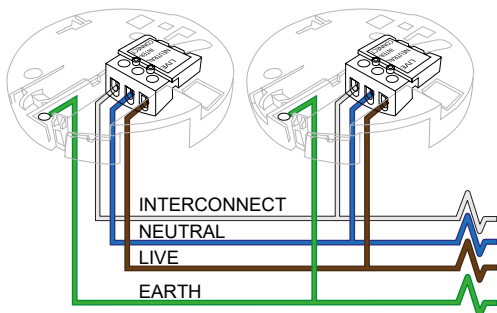

**FIGURE 5 – WIRING & INTERCONNECT FACILITY**

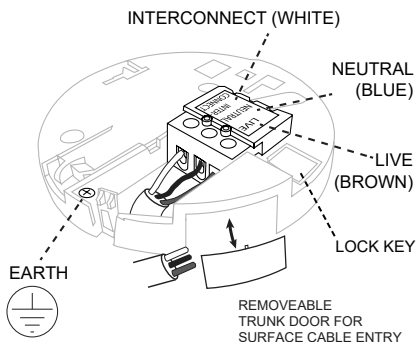

**FIGURE 6 – REMOVE WIRING COVER**

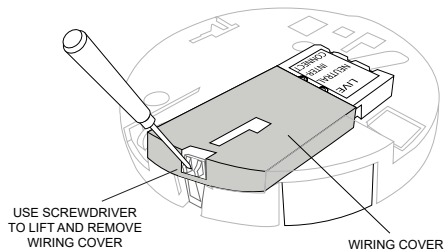

**FIGURE 7 – LOCKING THE ALARM UNIT WITH THE BASE**

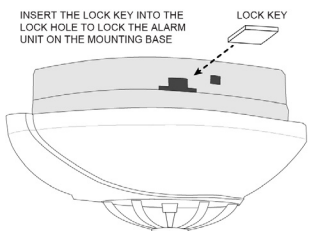

**FIGURE 8 – USE SCREW TO PICK OUT THE LOCK KEY FROM THE MOUNTING BASE**

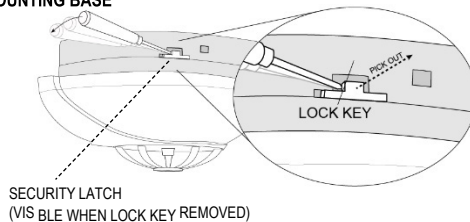

**OPERATING YOUR CO ALARM**

Once the alarm has been installed a small GREEN indicator light (LED) should be visible through the alarm grill indicating that AC supply is healthy. A RED indicator light (LED) should also flash approximately once a minute to indicate the battery is healthy and the unit is operating properly.

When the apparatus detects dangerous levels of CO gas, it will give an alarm signal. The red LED will flash and the sounder will chirp 6 times simultaneously every second.

After 30 minutes, when the apparatus remains alarming, the red LED will flash and the sounder will chirp 6 times simultaneously every minute. During alarming, the green LED will flash once every 10 seconds.

CO LEVEL (PPM)	RESPONSE TIME (MIN)
50	60-90
100	10-40
300	< 3

**WARNING - This product may not alarm at low carbon monoxide levels. Individuals with medical problems may consider using warning devices which provide audible signals for carbon monoxide concentrations under 30 PPM.**

Never ignore a CO unit's alarm. A true alarm is an indication of potentially dangerous levels of carbon monoxide. CO alarms are designed to alert you to the presence of carbon monoxide before an emergency, before most people would experience symptoms of carbon monoxide poisoning, giving you time to resolve the problem calmly.

**Unit Malfunction**

Your CO alarm performs an internal self-diagnosis every minute to make sure that it is functioning properly. In the rare event that your alarm malfunctions, the apparatus will sound a double short chirp and the yellow LED flash simultaneously every minute. In this case the alarm must be replaced.

**LOW BATTERY WARNING**

If the alarm emits a short 'beep' once a minute the battery is at the end of its life. This low voltage warning will be given for at least 30 days.

In this case, the other interconnected units in the system which are not in low battery condition will chirps for a few seconds once an hour as long as the detector with the "dead" battery beeps. If the red indicator light (LED) does not flash every minute then replace the battery .

**ALARM AND SOUND INDICATORS**

<b>FIRE WARNING</b>	• Alarm sounds and the red LED is blinking rapidly.
<b>LOW BATTERY WARNING</b>	• One audible beep every 40 to 60 seconds. • Press the silence feature button to activate the silence mode of unit itself for 10 hours
<b>FAULT WARNING</b>	• Two audible beeps every 40 to 60 seconds. • Press the silence feature button to activate the silence mode of unit itself for 10 hours

**BATTERY REPLACEMENT**

If the CO Alarm emits a short 'beep' once a minute the battery is at the end of its life and should be replaced immediately. This low voltage warning will be given for at least 30 days. Always TURN OFF the A.C. supply to the apparatus before replacing the battery.

Each time after replacing with a new battery, the user has to test the alarm by pressing the test button to ensure the detector is working correctly

- Unlock the apparatus unit from the base by pushing up the temporary latch with a screw driver
- Remove the old battery from the compartment.
- Insert a new, healthy 9V battery. NOTE POLARITY OF CONNECTIONS.
- Using the Push to Test button to test the CO Alarm. See "TESTING YOUR CO ALARM"
- Reattach the CO alarm to the mounting base

**WHAT TO DO IF THE ALARM SOUNDS**

WARNING - Actuation of your CO alarm indicates the presence of carbon Monoxide (CO), which can KILL YOU. If alarm signal sounds:

- Immediately move to fresh air
- Where possible turn off all fuelled appliances and stop using them.
- Call your emergency services
- Do not re-enter the premises until emergency services responders have arrived, the premises have been aired out, and your alarm remains in its normal condition.
- Call a qualified appliance technician to investigate for sources of CO from fuel burning equipment and appliances, and inspect for proper operation of this equipment. If problems are identified during this inspection have the equipment serviced immediately. Note any combustion equipment not inspected by the technician and consult the manufacturers' instructions, or contact the manufacturers directly, for more information about CO safety and this equipment. Make sure that motor vehicles are not, and have not been, operating in an attached garage or adjacent to the residence.

**MAINTAINING YOUR CO ALARM**

Your alarm will alert you to potentially hazardous CO concentrations in your home when maintained properly. To maintain your alarm in proper working order, it is recommended that you clean the outside case regularly to prevent dust or dirt build up in the slots. DO NOT USE CLEANING AGENTS, BLEACH, POLISH OR ANY CHEMICALS. Chemicals can permanently damage or temporarily contaminate the sensor. Simply wipe with a damp cloth OR a clean tissue.

**NOTE -** If you will be staining or stripping wood floors or furniture, painting, wall-papering, or using aerosols or adhesives, remove the CO alarm to a remote location before in order to prevent possible damage to or contamination of the sensor.

The following is a list of substances which, at high levels, can affect the sensor and may cause a nuisance alarm that is not a carbon monoxide alarm: Methane, propane, iso-butane, ethylene, ethanol, alcohol, iso-propanol, benzene, toluene, ethyl acetate, hydrogen, hydrogen sulfide, sulfur dioxides. Also most aerosol sprays, alcohol based products, paints, solvents, adhesives, hair sprays, after shaves, perfumes and some cleaning agents.

**SYMPTOMS OF CO POISONING**

The following symptoms may be related to CO poisoning:

35 ppm	The maximum allowable concentration for continuous exposure for healthy adults in any 8 hour period.
200 ppm	Slight headaches, fatigue, dizziness, nausea after 2-3 hours
400 ppm	Frontal headaches within 1-2 hours, life threatening after 3 hours.
800 ppm	Dizziness, nausea and convulsions within 45 minutes. Unconsciousness within 2 hours. Death within 3 hours
1600 ppm	Headache, dizziness and nausea within 20 minutes Death within 1 hour
6400 ppm	Headache, dizziness and nausea within 1-2 minutes

**IMPORTANT SAFEGUARDS**

Installation of your CO alarm is only one step in your safety plan. Educate yourself and family to the sources and symptoms of CO poisoning and how to use your carbon monoxide alarm:

- Buy appliances accepted by a recognized testing laboratory.
- Have installations done by professionals.
- Have your appliances checked regularly by a qualified serviceman.
- Clean chimneys and flues yearly.
- Make regular visual inspections of all-fuel-burning appliances.
- Check appliances for excessive rust and scaling.
- Do not barbecue indoors, or in attached garage.
- Be aware of CO poisoning symptoms.

THIS PRODUCT IS A SEALED UNIT AND CANNOT BE REPAIRED – IF THE UNIT IS TAMPERED WITH IT WILL INVALIDATE THE WARRANTY. IF THE UNIT IS FAULTY PLEASE RETURN IT TO YOUR ORIGINAL SUPPLIER WITH YOUR PROOF OF PURCHASE.

**ALARM LIMITED WARRANTY**

This alarm is in warranty under normal use and service for a period of 5 years (excluding battery) from date of purchase. The company will not be obligated to repair or replace parts which are found to be in need of repair because of misuse, damage or alterations occur after the date of purchase. Send the alarm with proof of purchase, postage and return postage prepaid, to local distributor. The liability of the company arising from the sale of this alarm shall not in any case exceed the cost of replacement of alarm and in no case shall the company be liable for consequential loss or damages resulting from the failure of the alarm.

HISPEC ELECTRICAL PRODUCTS LTD. SHALL HAVE NO LIABILITY FOR ANY PERSONAL INJURY OR PROPERTY DAMAGE, OR ANY SPECIAL INCIDENTAL, CONTINGENT OR CONSEQUENTIAL DAMAGE OF ANY KIND RESULTING FROM A FIRE. THE EXCLUSIVE REMEDY FOR BREACH OF THE LIMITED WARRANTY CONTAINED HEREIN IS THE REPAIR OR REPLACEMENT OF THE DETECTIVE PRODUCT AT HISPEC ELECTRICAL PRODUCTS LTD. OPTION. IN NO CASE SHALL HISPEC ELECTRICAL PRODUCTS LTD.'S LIABILITY UNDER ANY OTHER REMEDY PRESCRIBED BY LAW EXCEED THE PURCHASE PRICE. YOUR ALARM IS NOT A SUBSTITUTE FOR PROPERTY, DISABILITY, LIFE OR OTHER INSURANCE OF ANY KIND. APPROPRIATE COVERAGE IS YOUR RESPONSIBILITY. CONSULT YOUR INSURANCE AGENT.

This does not affect your statutory rights. This alarm is only suitable for residential dwellings and is not suitable for commercial or industrial use. Waste electrical products should not be disposed of with normal household waste. Please recycle where facilities exist. Check with your Local Authority or retailer for recycling advice. New regulation will encourage the recycling of Waste from Electrical and Electronic Equipment (European "WEEE Directive" effective August 2005).