

Assembly Instructions



Email : Sales@shelters4less.co.uk
Web : www.shelters4less.co.uk
Tel : 0800 160 1002







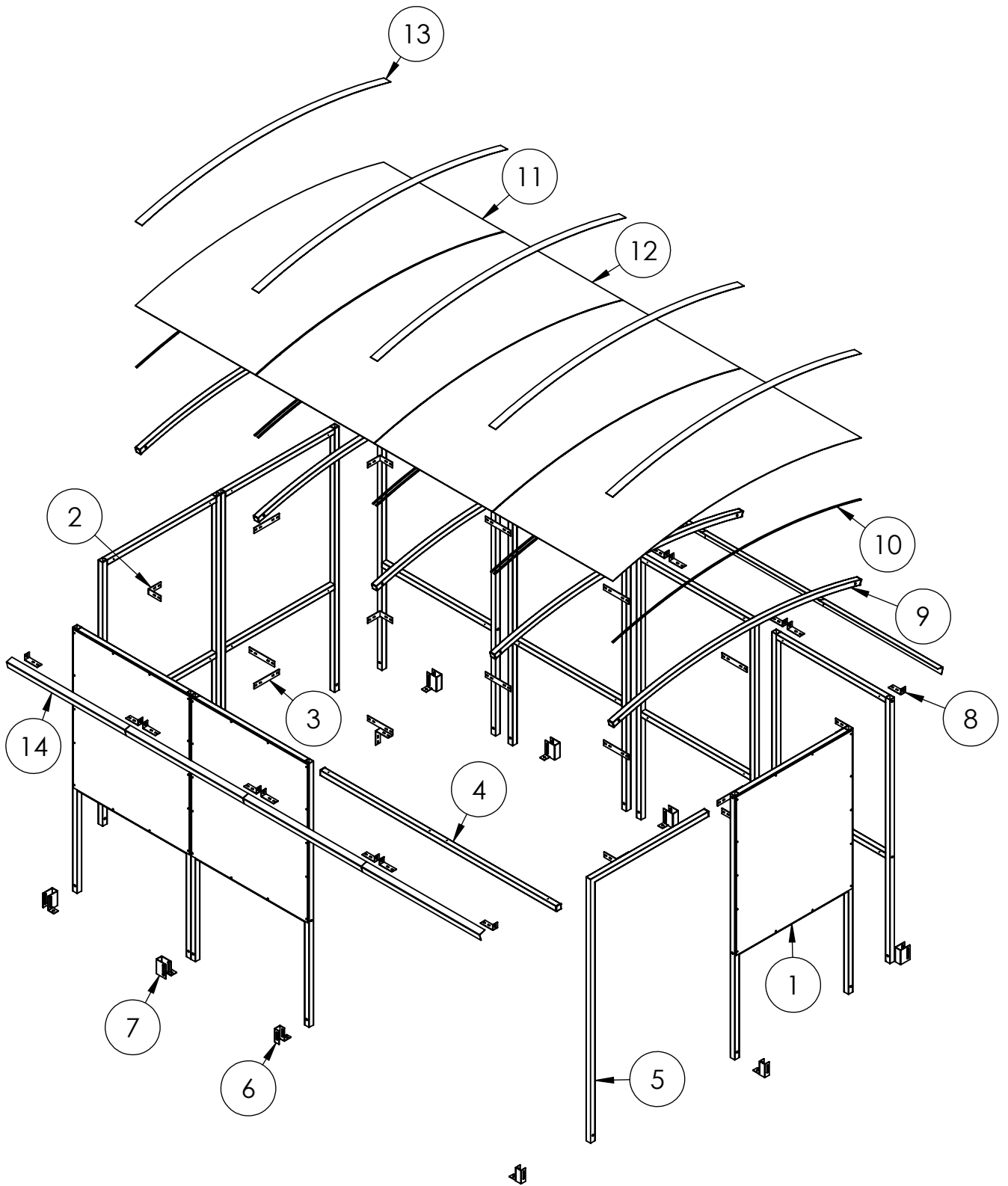

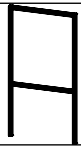

Shelter type: SR1563

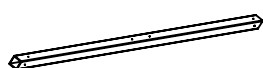
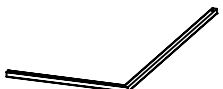
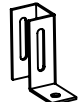
SR1563-02-100119-UK

EXPLODED VIEW

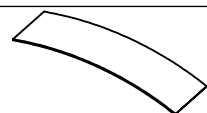

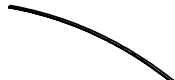
PARTS LIST

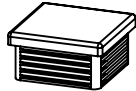
ITEM NO.	PART NO.	DESCRIPTION	DIMENSION (MM)	DIMENSION (INCHES)	IMAGE	QTY.
1	S1	Frame	2000 x 1035	78.74 x 40.55		9
2	CB1	Bracket	110 x 110	4.33 x 4.33		8
3	JF1	Bracket	220 x 40	8.66 x 1.58		12
4	ST3	Roof Tie	2060 x 40 x 40	81.10 x 1.57 x 1.57		1
5	P1	Post	2000 x 1030	40.55 x 78.74		1
6	FT1	Foot Bracket	109 x 110 x 40	4.29 x 3.93 x 1.57		3
7	FT3	Foot Bracket	109 x 100 x 80	4.29 x 3.93 x 3.27		8
8	RB1	Bracket	1050 x 1150	4.33 x 1.81		16
9	R2	Rafter	2200 x 40 x 40	87.40 x 40.55		5
10	SS	Sealing Strip	Trim To 2195	Trim To 86.61		4 ROLLS
11	ACE2	Roof Panel	2210 x 1050	87 x 41.34		2
12	ACC2	Roof Panel	2210 x 1030	87 x 40.55		2
13	RC2	Roof Strip	2200	87.40		5
14	A2	Roof Edge Angle	40.55 x 1.97 x 1.97	Trim To Fit		8
15	EC40	Plastic End Cap	40 x 40	1.57 x 1.57		24

Fittings/Tools

	Bolt set M10				T25	AB1210
	M10 x 60 mm	Nut	Washer	Black Cap	25 mm Tech screw	M10/12 x 100mm Concrete Bolt
Pack C+D	40	40	80	80	202	13
Required	21	21	42	42	162	11
Image						

Tools required:



Drill/Screwdriver



Mallet



Hack saw



Spanner



Torx bit

Step 1 Assemble **S1** frames to make up the main structure using **CB1** brackets for the corners and **JF1** brackets for the straight joints.

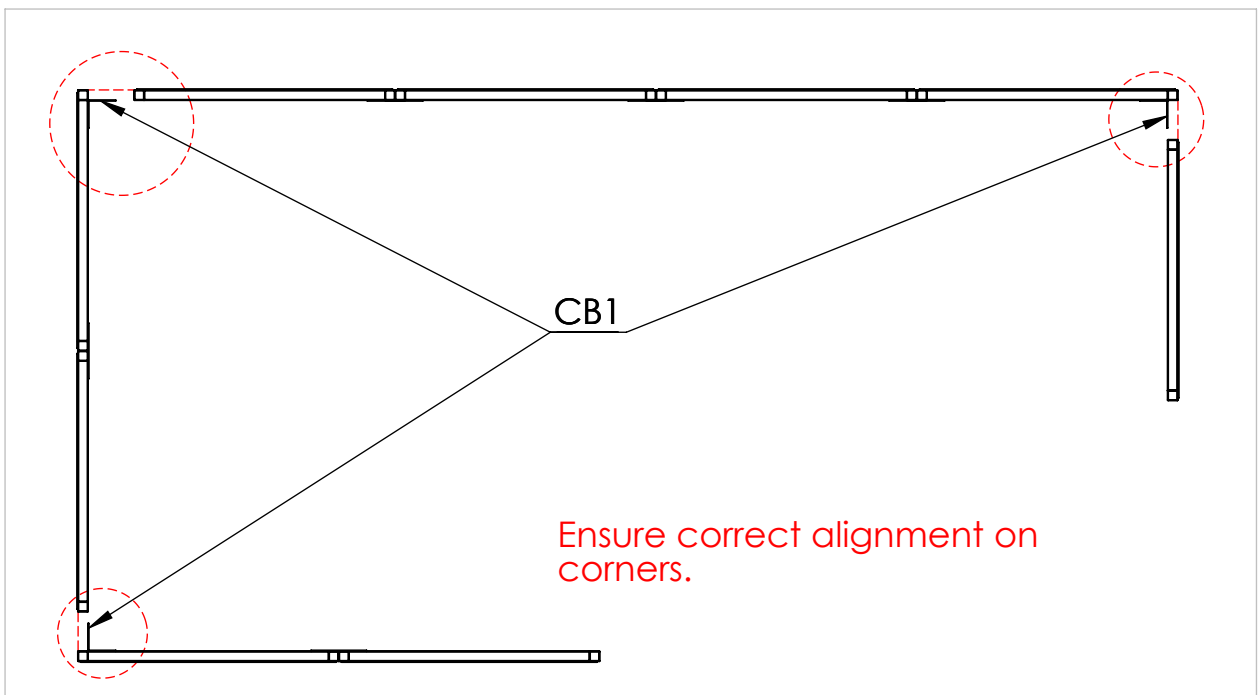
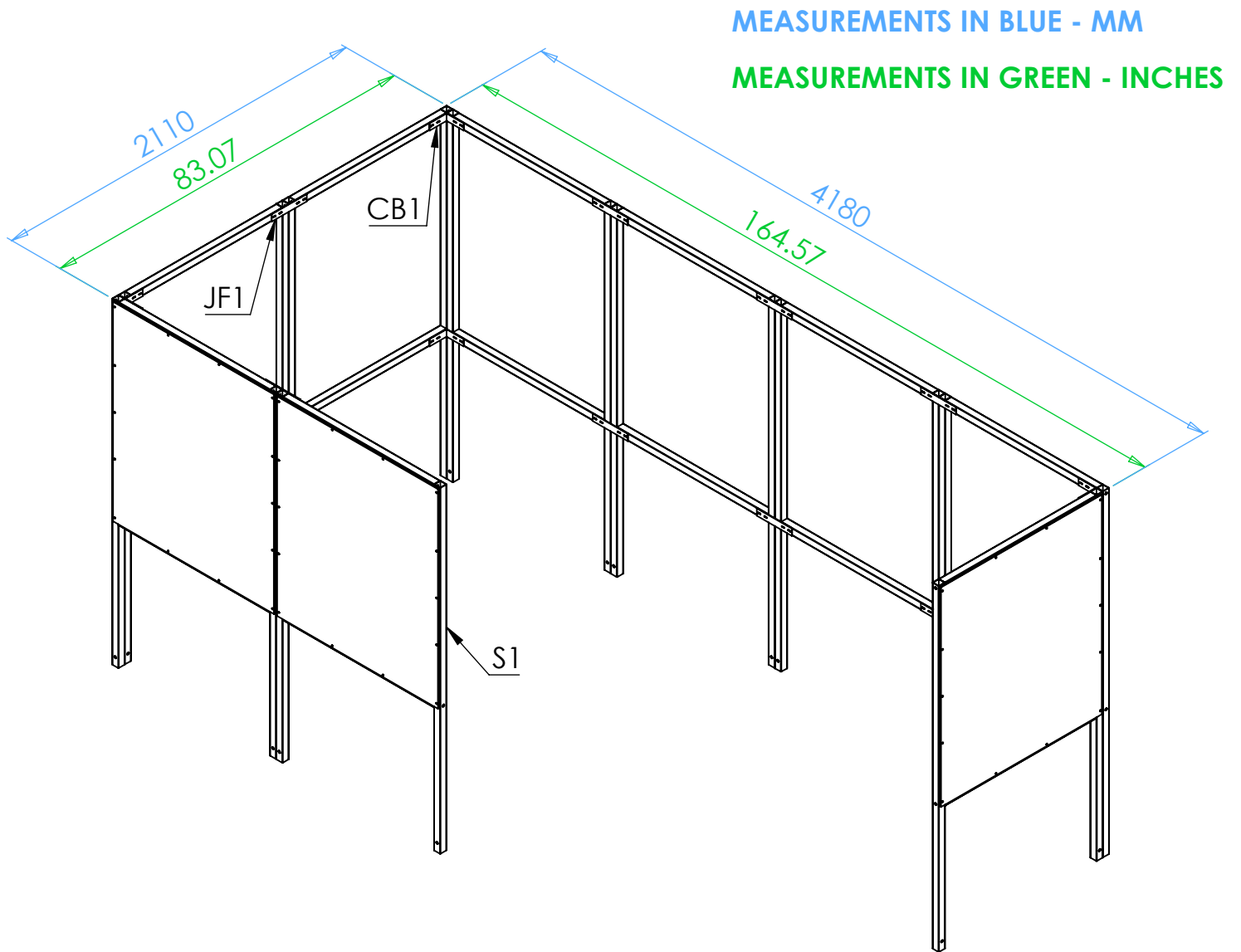

Step 2 Attach **P1** post using one **JF1** bracket, then attach **ST3** tie bar using another **JF1** bracket and two **CB1** brackets. Move the shelter to its final position, make sure the structure is square and attach the **FT1** and **FT3** foot brackets to secure the shelter to the ground.

NOTE: Attach **EC40** to **P1** and **ST3** before installing.

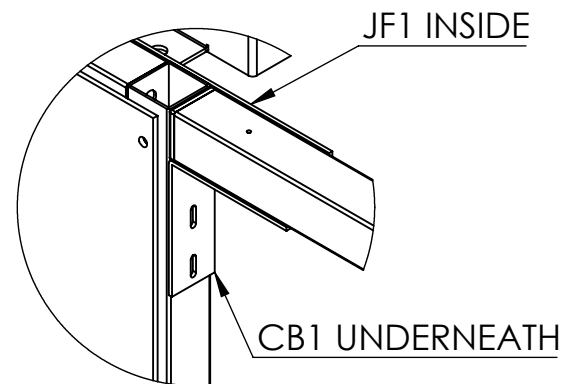
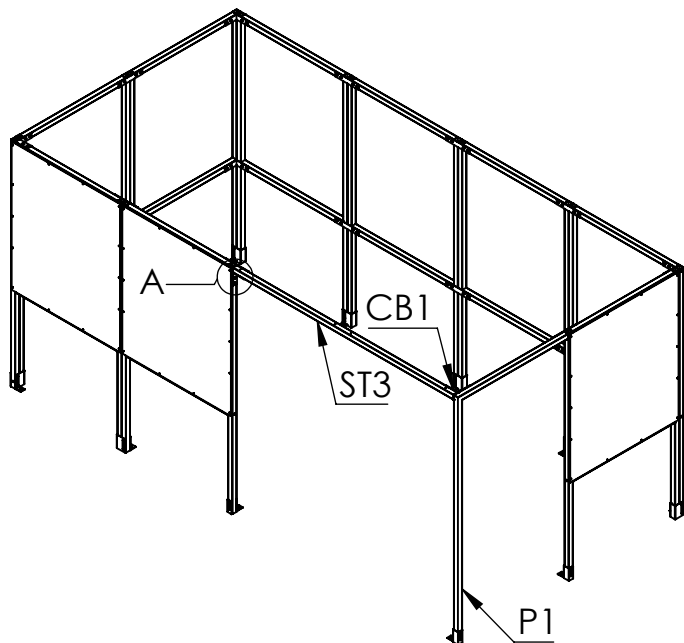
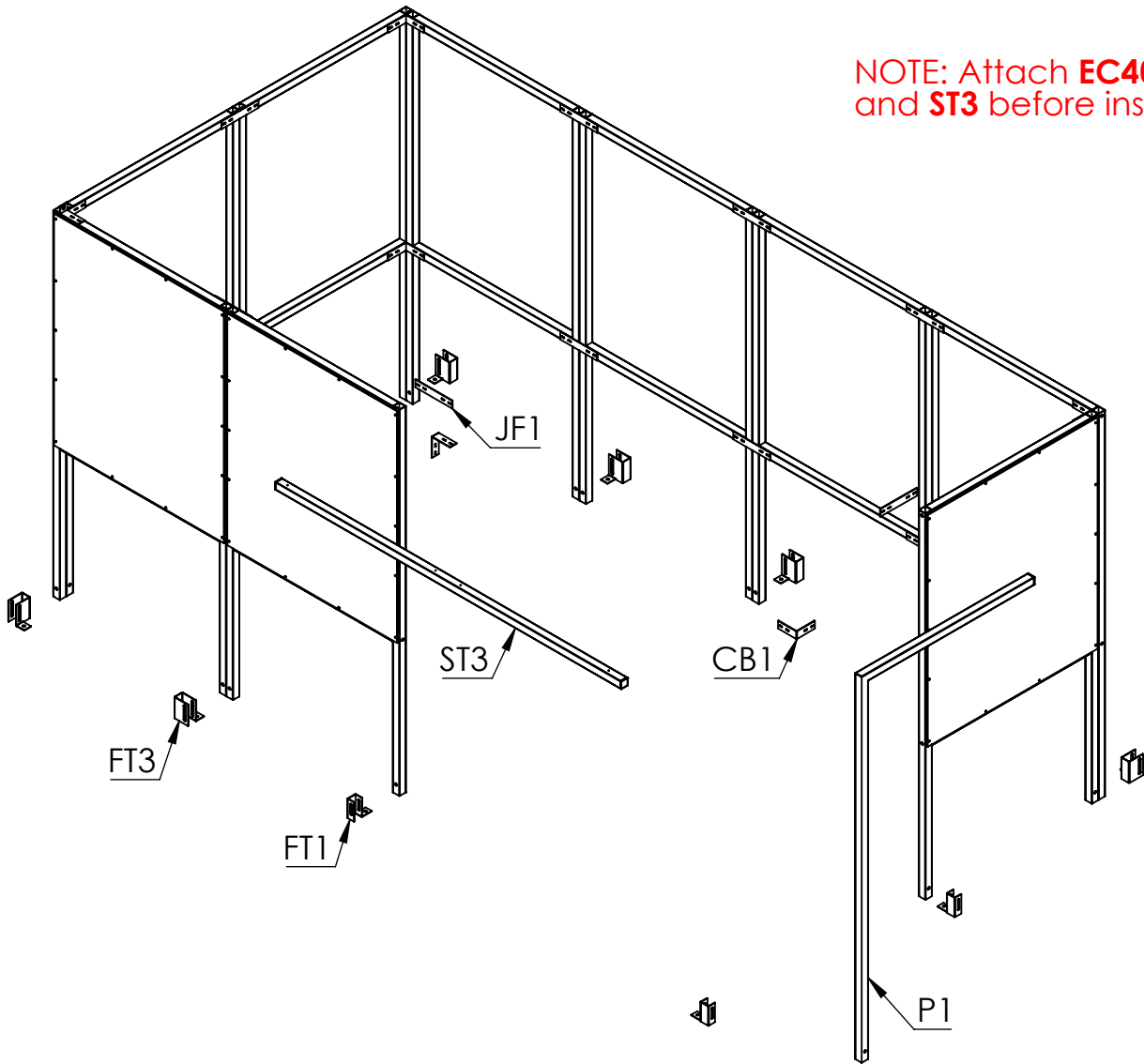

DETAIL A
SCALE 1 : 5

Step 3 Use **RB1** brackets to secure the **R2** roof rafters.

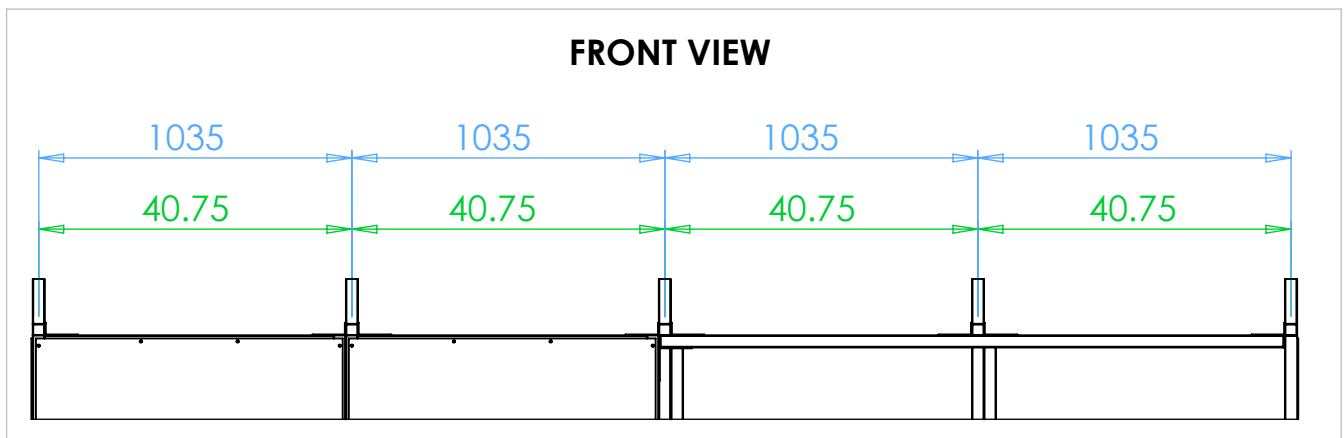
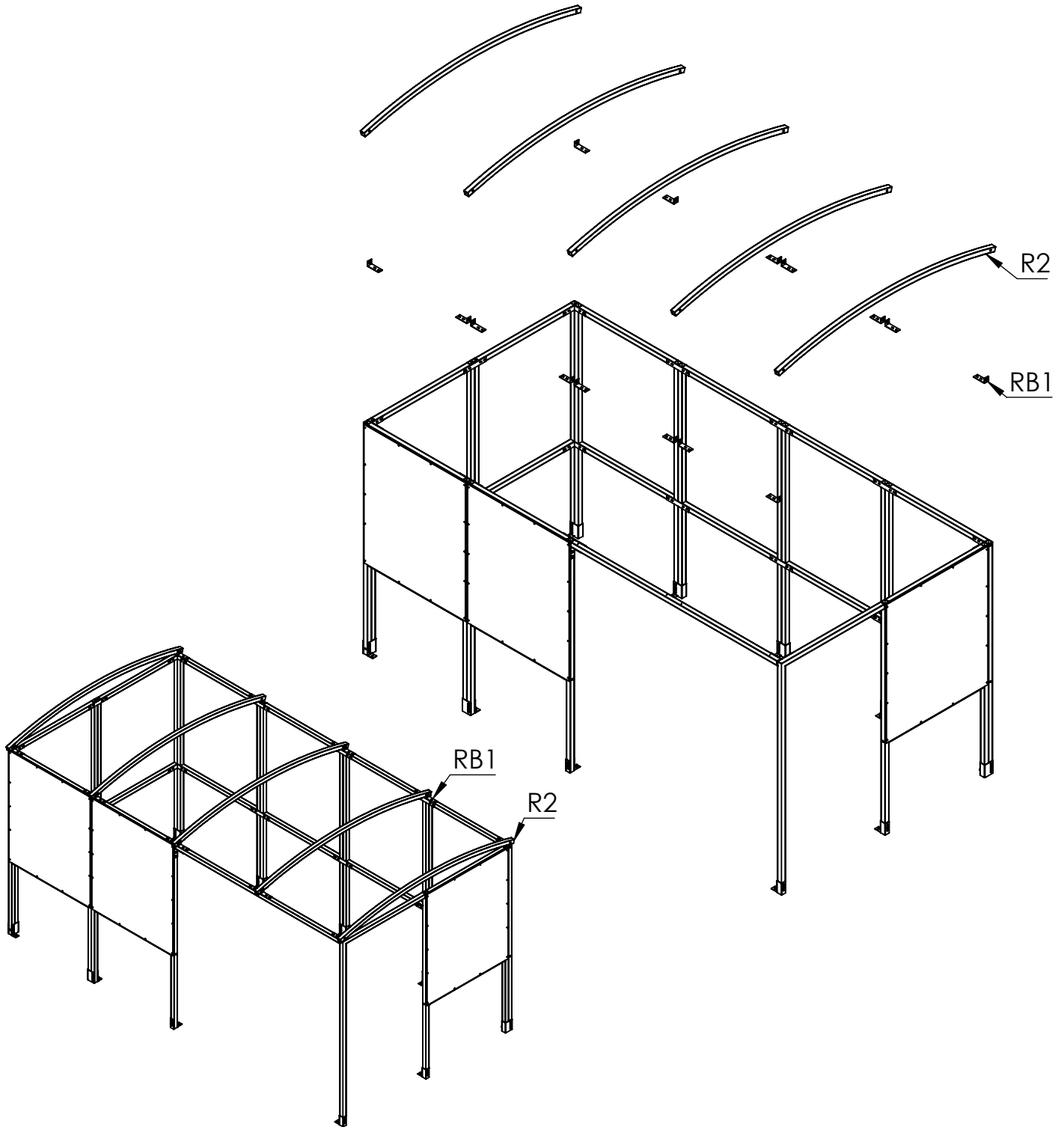

Step 4 Apply sealing strips (**SS**) to the top of the rafters. Align **ACE2** roof panels with the outer rafters then space out the **ACC2** panels evenly. Cover the two edges along the outer rafters and gaps with **RC2** strips before screwing them into place using the **25mm TEC screws**.

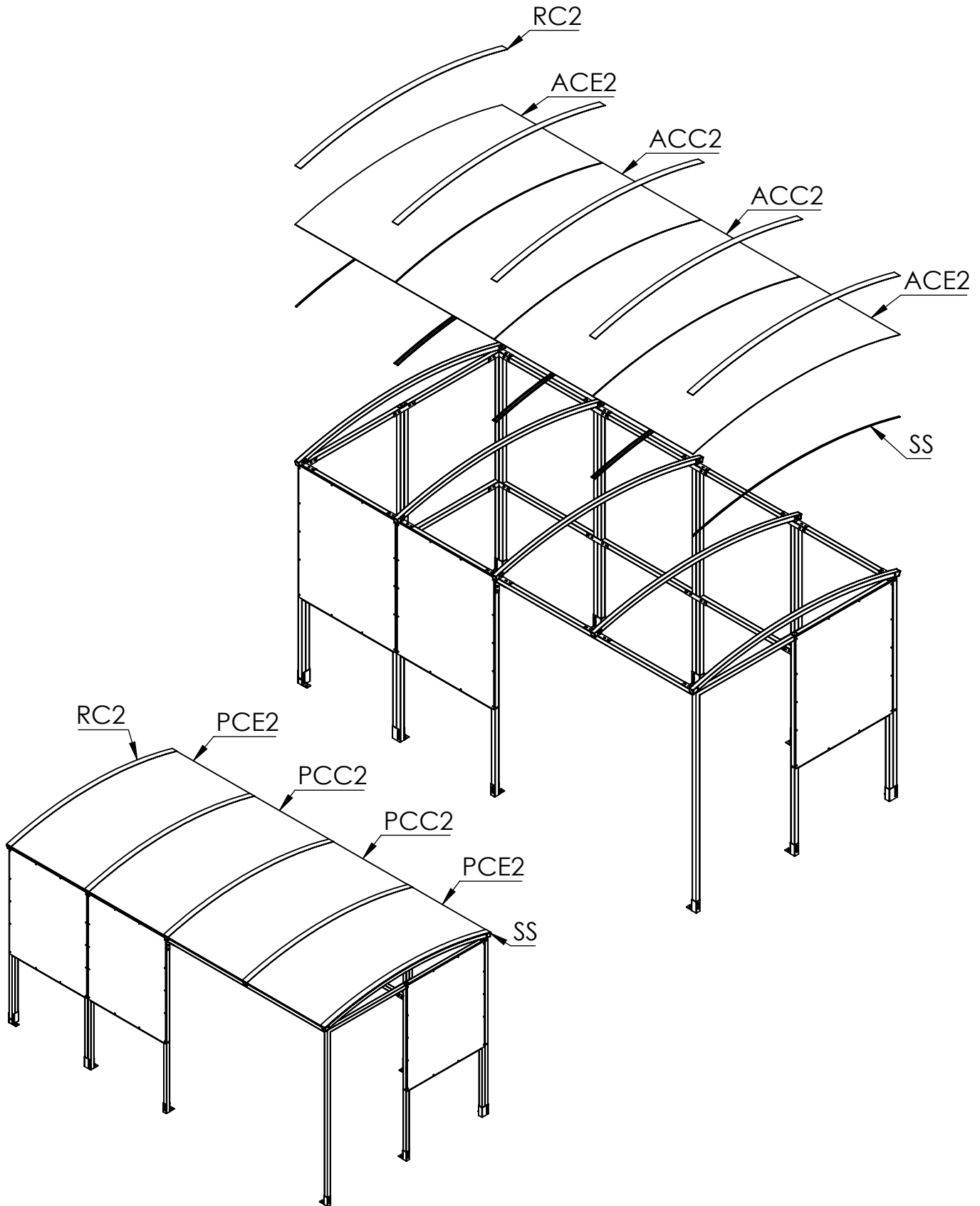

Step 5 Fit the square end caps (**EC40**) to any open ends of box sections. Screw **A2** roof angles onto the edges of the roof as shown below.

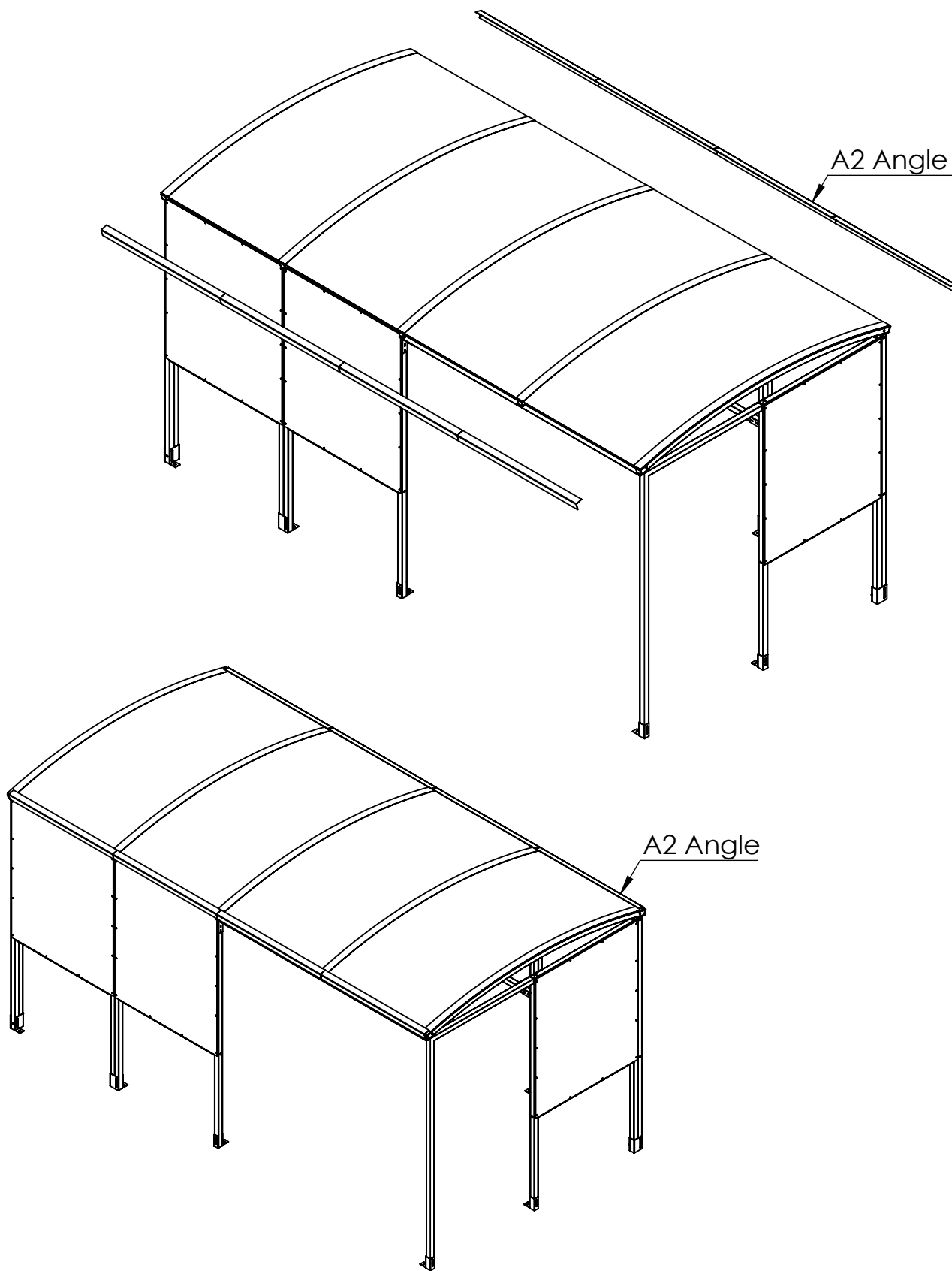

NOTES:

THANK YOU FOR PURCHASING THIS PRODUCT

MAINTENANCE:

To ensure your products give you many years of use we recommend that you:

- Clean panels regularly with soapy water
- Ensure all fittings are tight (for example after a big storm)
- Touch up any exposed metal should it get scratched

CONTACT DETAILS:

Email : Sales@shelter4less.co.uk

Web : www.shelters4less.co.uk

Tel : 0800 160 1002

Unit B, Sharp Road, Poole, BH12 4BG

All Parts and Fixings checked by:	
Print Name:	Signature: