

Assembly Instructions



No Butts Bin Co.
Better Ash & Trash Solutions
Est. 1991

Email : Sales@nobutts.com

Web : www.nobutts.com

Tel : 1-888-662-8887

Shelter type: SR8060-F

SR8060F-01-02112021-USA

Exploded view

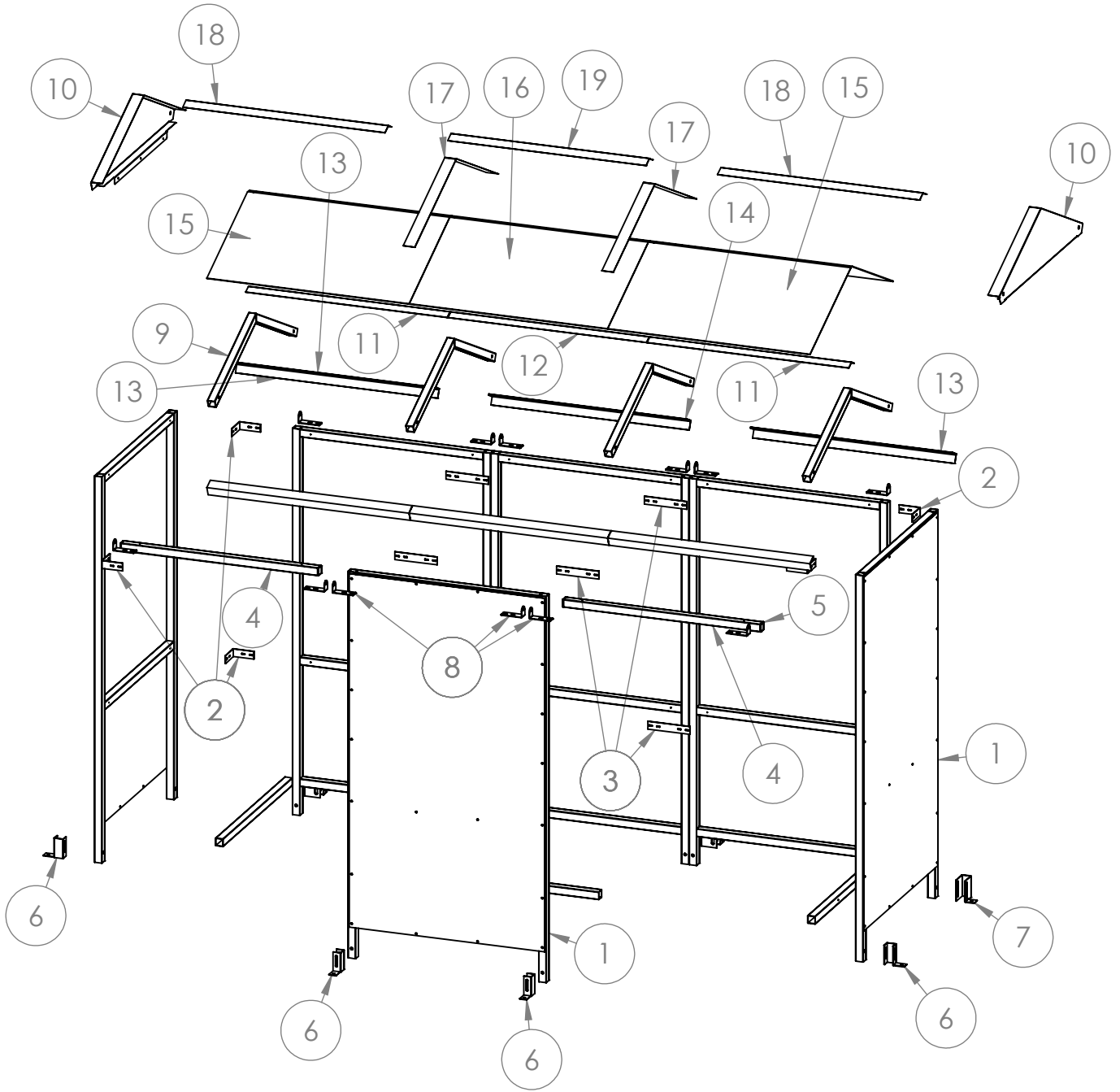

Tools required:



Drill/Screwdriver



17mm Wrench











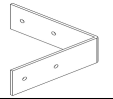
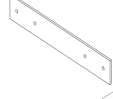

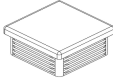

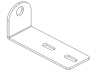

Mallet

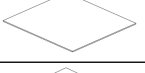

T25 Torx bit

PARTS LIST

| ITEM NO. | PART NAME | DRG NUMBER | Size (inch) | IMAGE | QTY. |
|----------|--|------------|--------------------|---|------|
| 1 | S1C Frame | S1C | 78.74 x 40.74 |  | 6 |
| 2 | CB1 Bracket | CB1 | 4.3 x 4.3 x 1.57 |  | 6 |
| 3 | JF1 Bracket | JF1 | 4.33 x 1.57 |  | 6 |
| 4 | ST1 Roof Tie | ST1 | 40.35 |  | 2 |
| 5 | 40x40 End cap | EC40 | 1.6 X 1.6 |  | 4 |
| 6 | FT1 Bracket | FT1 | 1.57 x 1.57 x 3.94 |  | 4 |
| 7 | FT3 Bracket | FT3 | 1.57 x 3.15 x 4.17 |  | 4 |
| 8 | DR Bracket | DR | 4.3 x 1.6 x 2 |  | 12 |
| 9 | AR1R 1m Pitch Rafter | AR1R | 45 x 11.8 OA |  | 4 |
| 10 | AR1IS 1m Pitch Infill Panel Shallow | AR1IS | 45.2 x 13.5 |  | 2 |
| 11 | AR1CLTO 1m Apex Roof Centre Lower Trim Outer | AR1CLTO | 41.4 |  | 2 |
| 12 | AR1CLTI 1m Apex Roof centre lower trim inner | AR1CLTI | 40.74 |  | 1 |
| 13 | Roof F Section Outer | ARFSO | 41.5 |  | 4 |
| 14 | ARFSI Apex Roof F Section Inner | ARFSI | 40.75 |  | 2 |
| 15 | AR1POA Roof Panel outer alu | AR1POA | 41.5 x 24.4 |  | 4 |
| 16 | AR1PIA Roof Panel inner ALU | AR1PIA | 40.75 x 24.4 |  | 2 |
| 17 | AR1TS 1m Apex Roof Trim strips | AR1TS | 24.8 x 2.3 |  | 4 |
| 18 | AR1CUTO 1m Apex Roof centre upper trim outer | AR1CUTO | 41.5 |  | 2 |
| 19 | AR1CUTI 1m Apex Roof centre upper trim inner | AR1CUTI | 40.75 |  | 1 |

FIXINGS

| Fittings | Bolt set M10 | | | T25 | T38 | | BTANCM12100 |
|-----------------|---|---|---|---|--|---|---|
| | M10 x 60mm | Nut | Washer | 1" Tech screw | 1.5" mm Tech screw | Black Caps | M10/12 x 100 mm Concrete Bolt |
| Pack A+B | 33 | 33 | 66 | 136 | 40 | 66 | 11 |
| Image |  |  |  |  |  |  |  |

Step 1 Assemble **S1C** frames to make up the main structure using **CB1** brackets for the corners and **JF1** brackets for the straight joints.

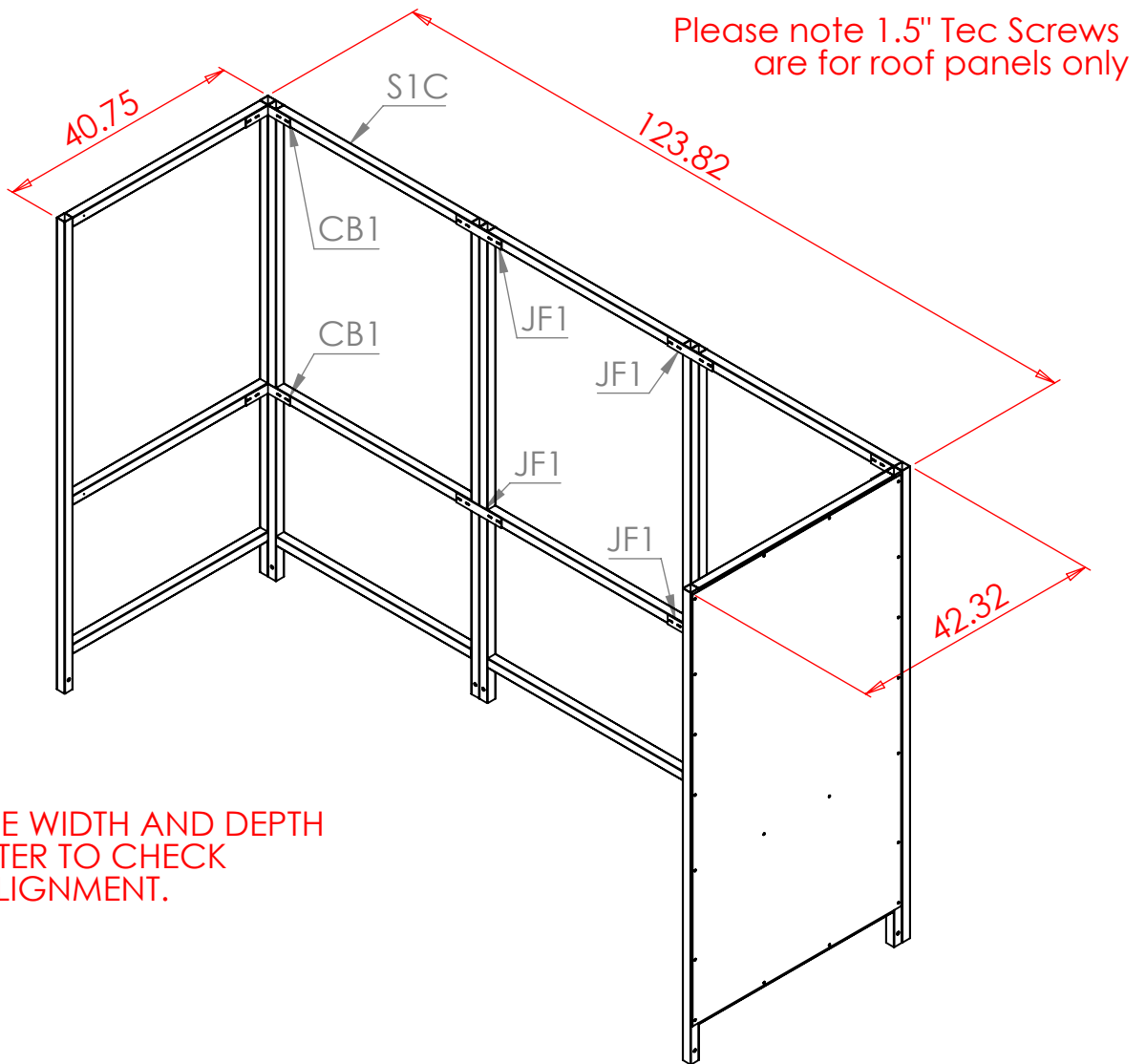

MEASURE THE WIDTH AND DEPTH OF THE SHELTER TO CHECK CORRECT ALIGNMENT.

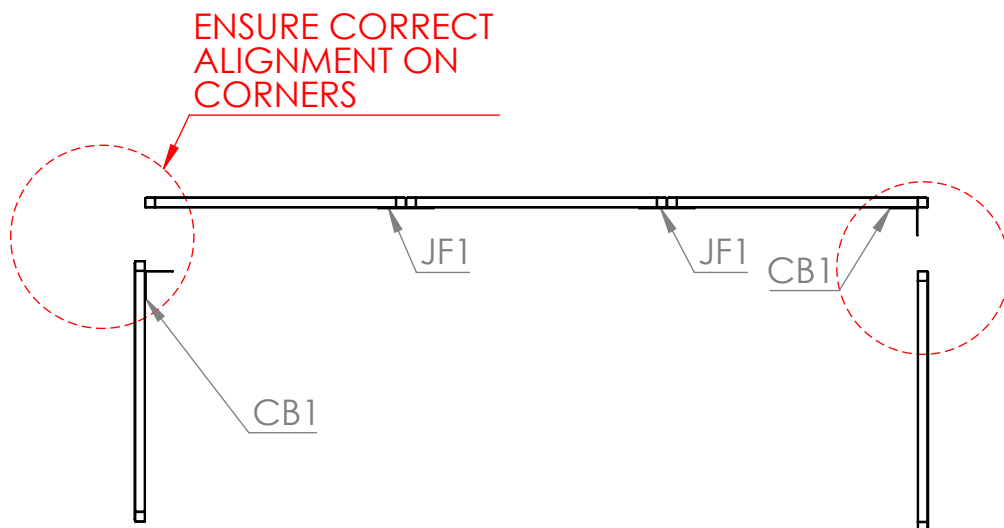

Step 2 Use **JF1** and **CB1** brackets to attach the **S1C** frame and **ST1** Tie bars.

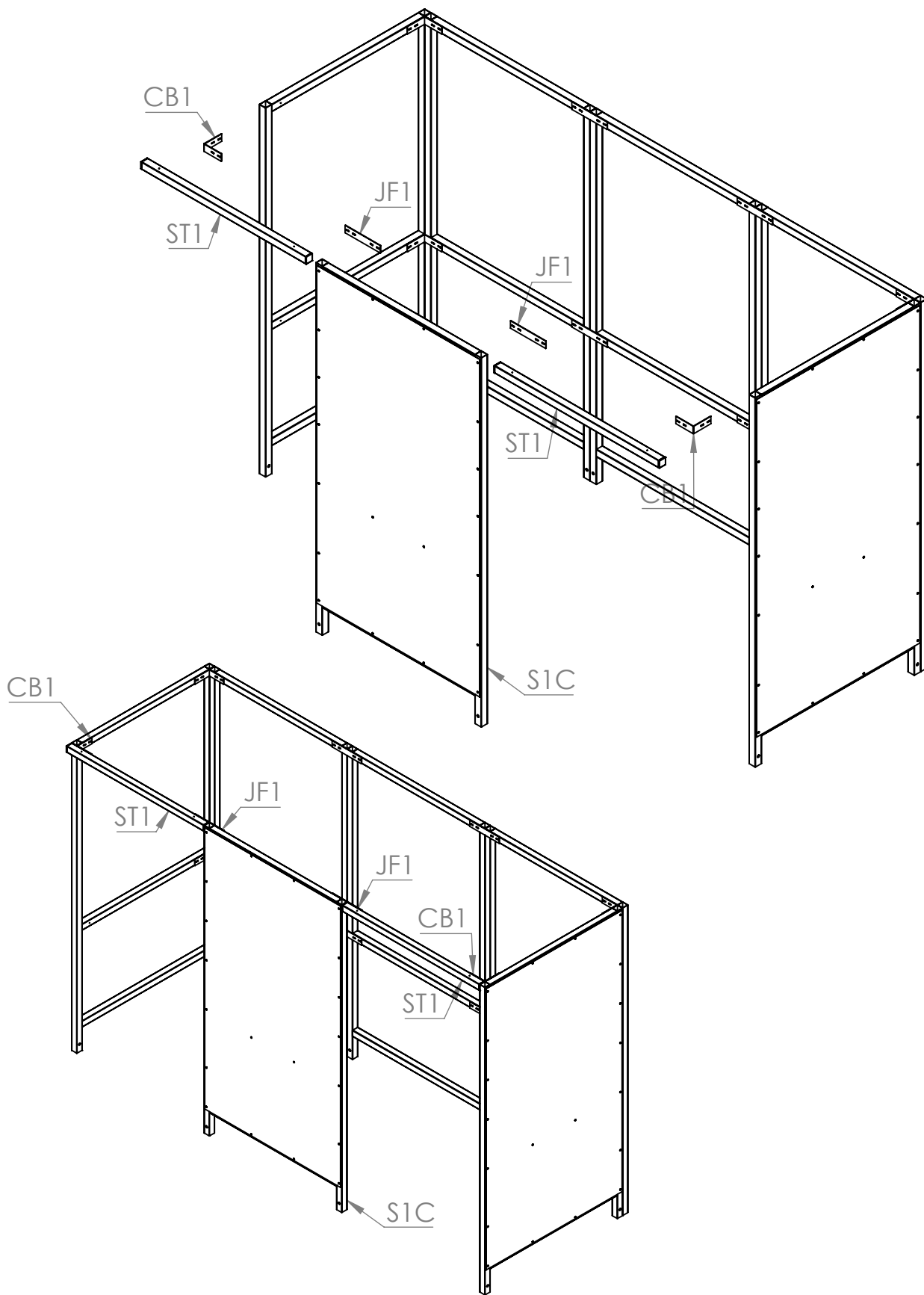

Step 3 Attach **AR1R** rafters using **DR** brackets. Secure the **AR1IS** end panels to **S1** frames using 1" tec screws. The end rafters need to be placed in position at the same time as the end panels.

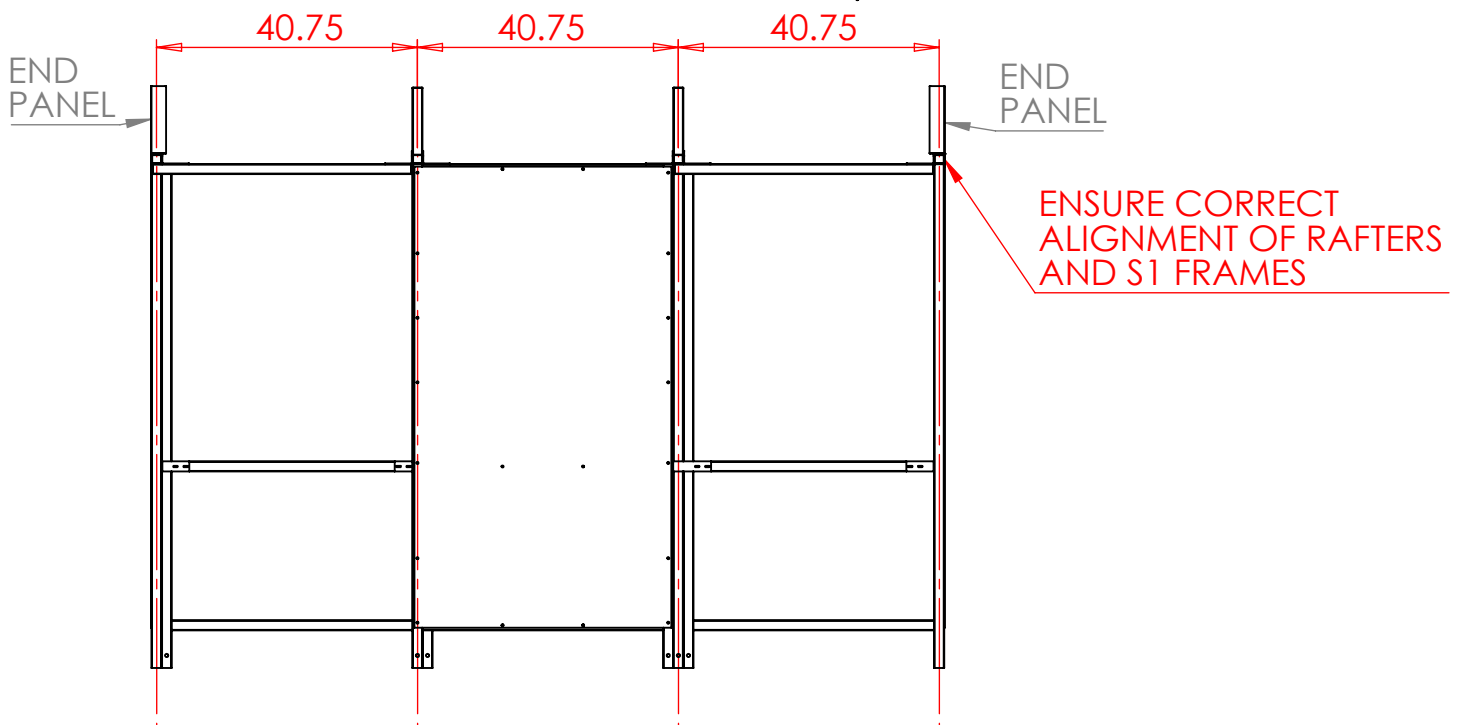
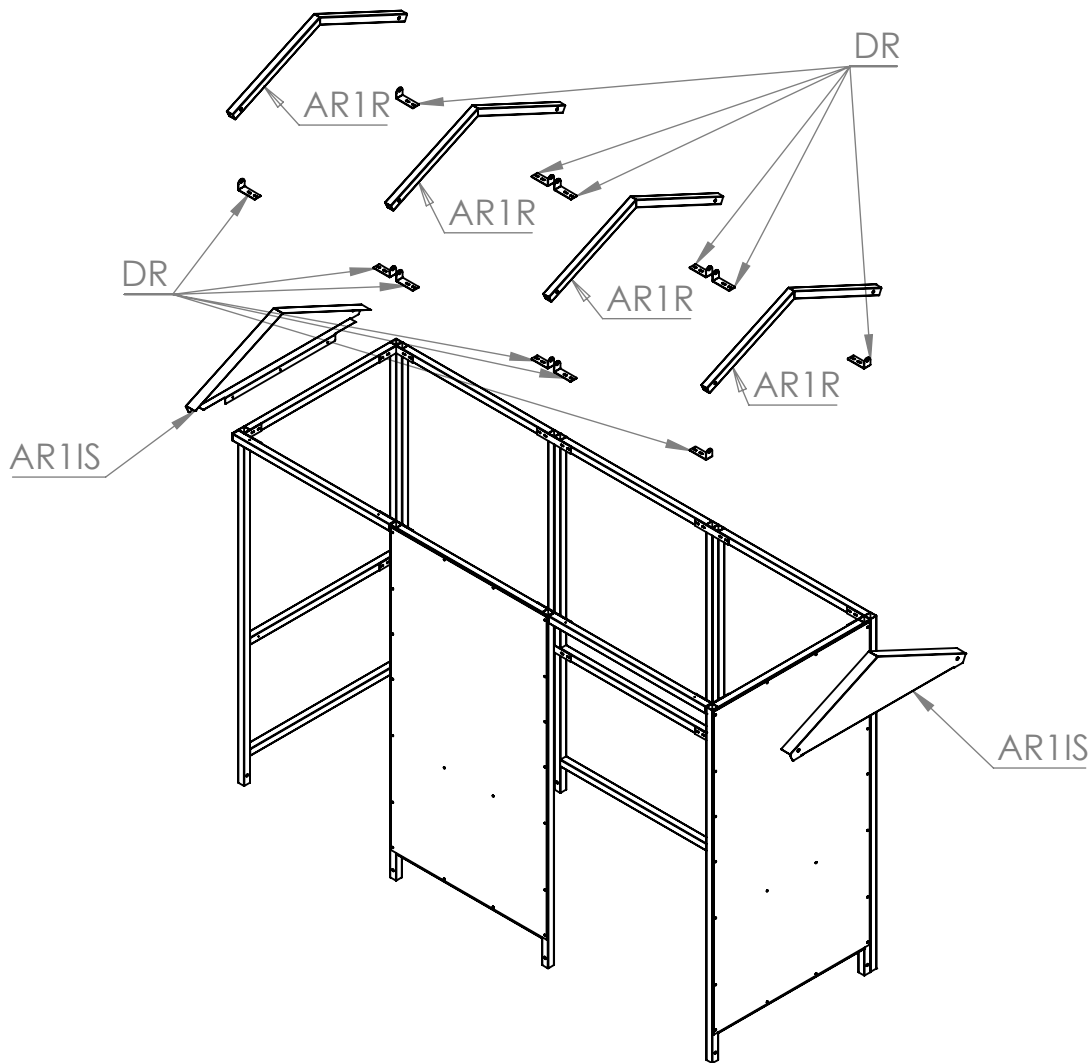

Step 4

Attach the **AR1CLTO** and **AR1CLTI** to the top of the rafters. The **AR1CLTO** are to be lined up near the end panels and the **AR1CLTI** have to be spaced centrally. The **ARFSO** and **ARFSI** parts are to be attached to the lower part of the rafters as shown below. Then the **ARSCLTI** and **ARSCLTO** are attached to the top of the rafters.

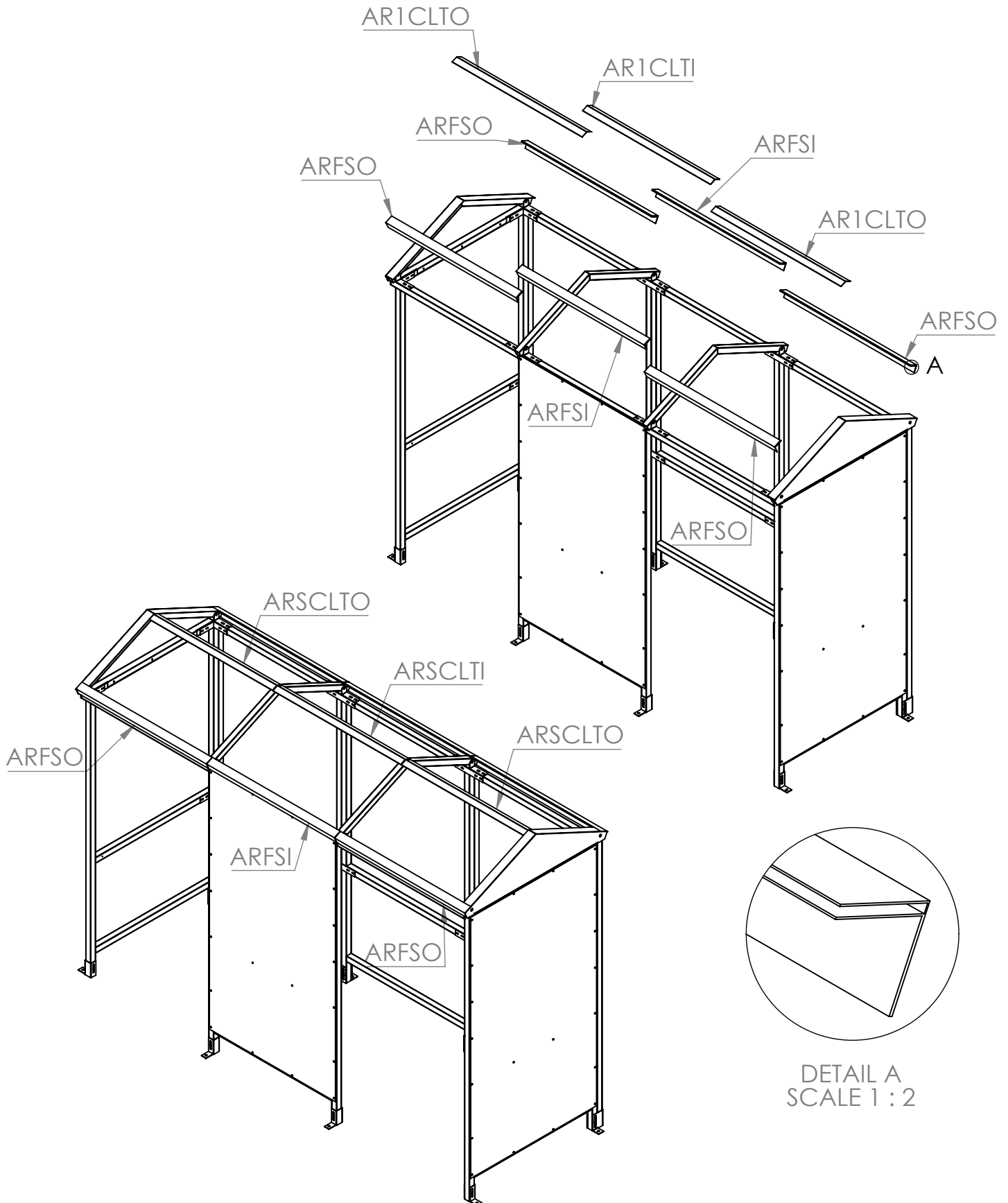

Step 5

Attach the **AR1POA** roof panels on the outer edges of the shelter nearest to the end panels and the **AR1PIA** panels need to be equally spaced along the centre.

Cap off the top using **AR1CUTO** and **AR1CUTI** as shown below. Use the **AR1TS** strips to cover the gaps between the panels.

Once the shelter is in the final position and square, it can be secured to the ground using the **FT3** and **FT1** brackets and concrete bolts.

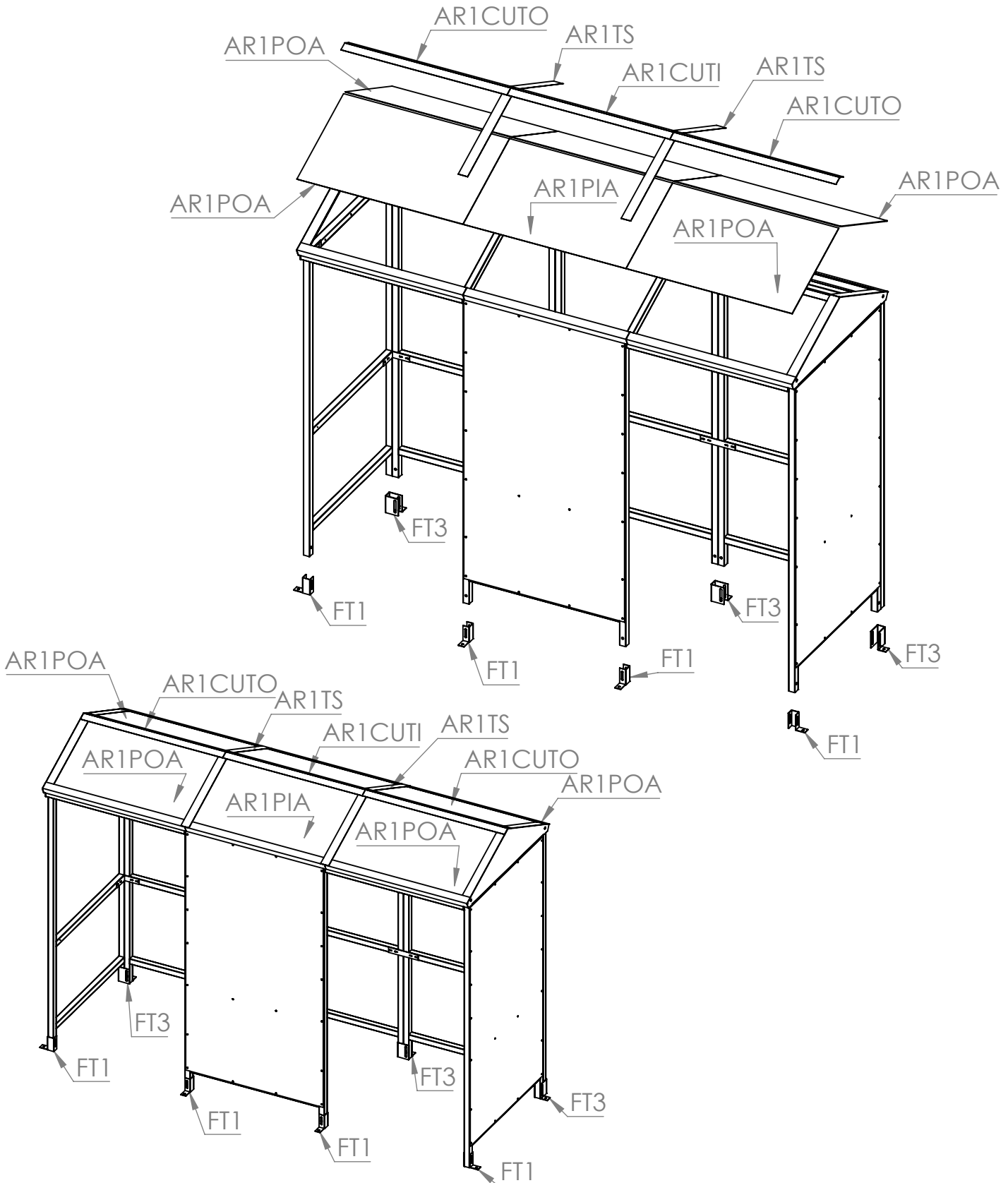

PLAN VIEW

OVERALL DIMENSIONS AND GROUND FIXING POSITIONS

Suggested size for concrete base: 8inch oversized on all 4 sides.

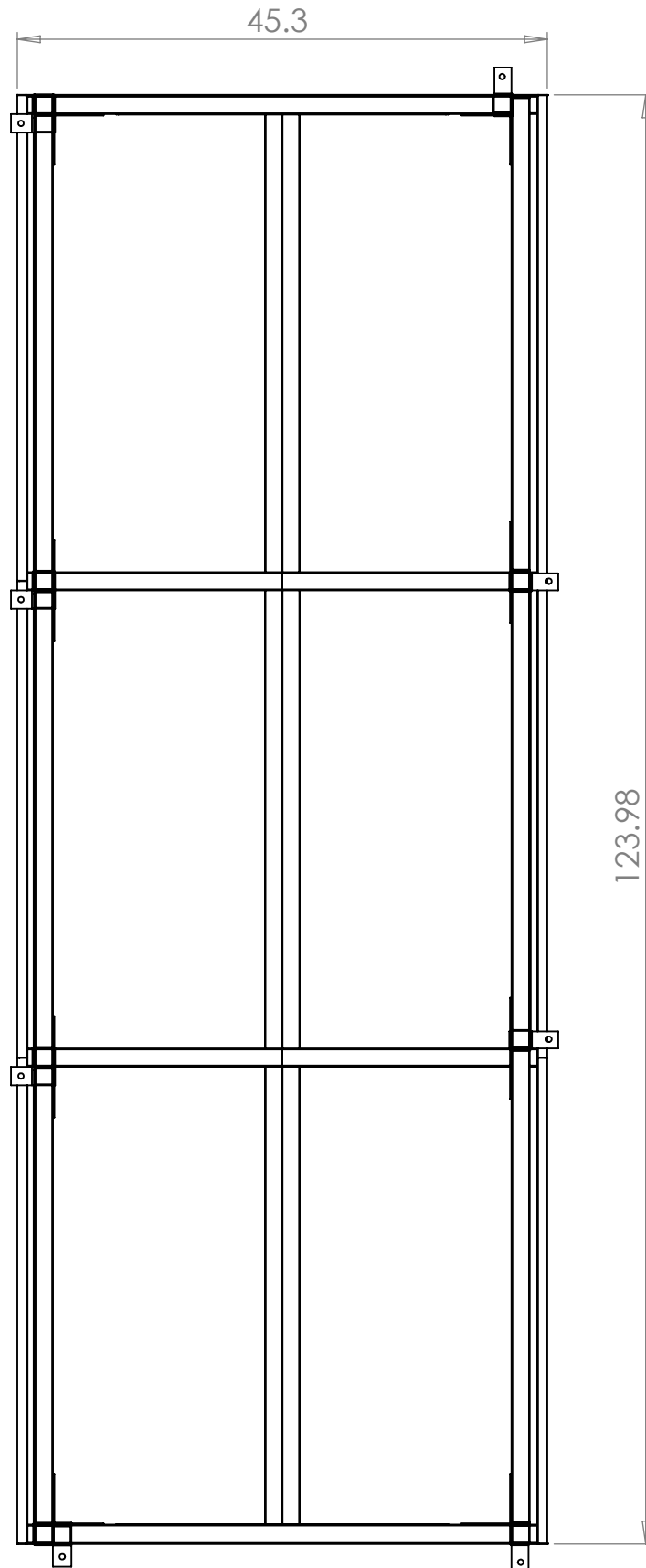

THANK YOU FOR PURCHASING THIS PRODUCT

MAINTENANCE:

To ensure your products give you many years of use we recommend that you:

- Clean panels regularly with soapy water
- Ensure all fittings are tight (for example after a big storm)
- Touch up any exposed metal should it get scratched

CONTACT DETAILS:

No Butts Bin Company, Inc.
16 Birch Lane, Madison, CT 06443

Email : Sales@nobutts.com

Web : www.nobutts.com

Tel : 1-888-662-8887

| | |
|--|------------|
| All Parts and Fixings checked by: | |
| Print Name: | Signature: |
| | |