

# Assembly Instructions



Email : [sales@nobutts.com](mailto:sales@nobutts.com)  
Web : [www.nobutts.com](http://www.nobutts.com)  
Tel : 1-888-662-8887







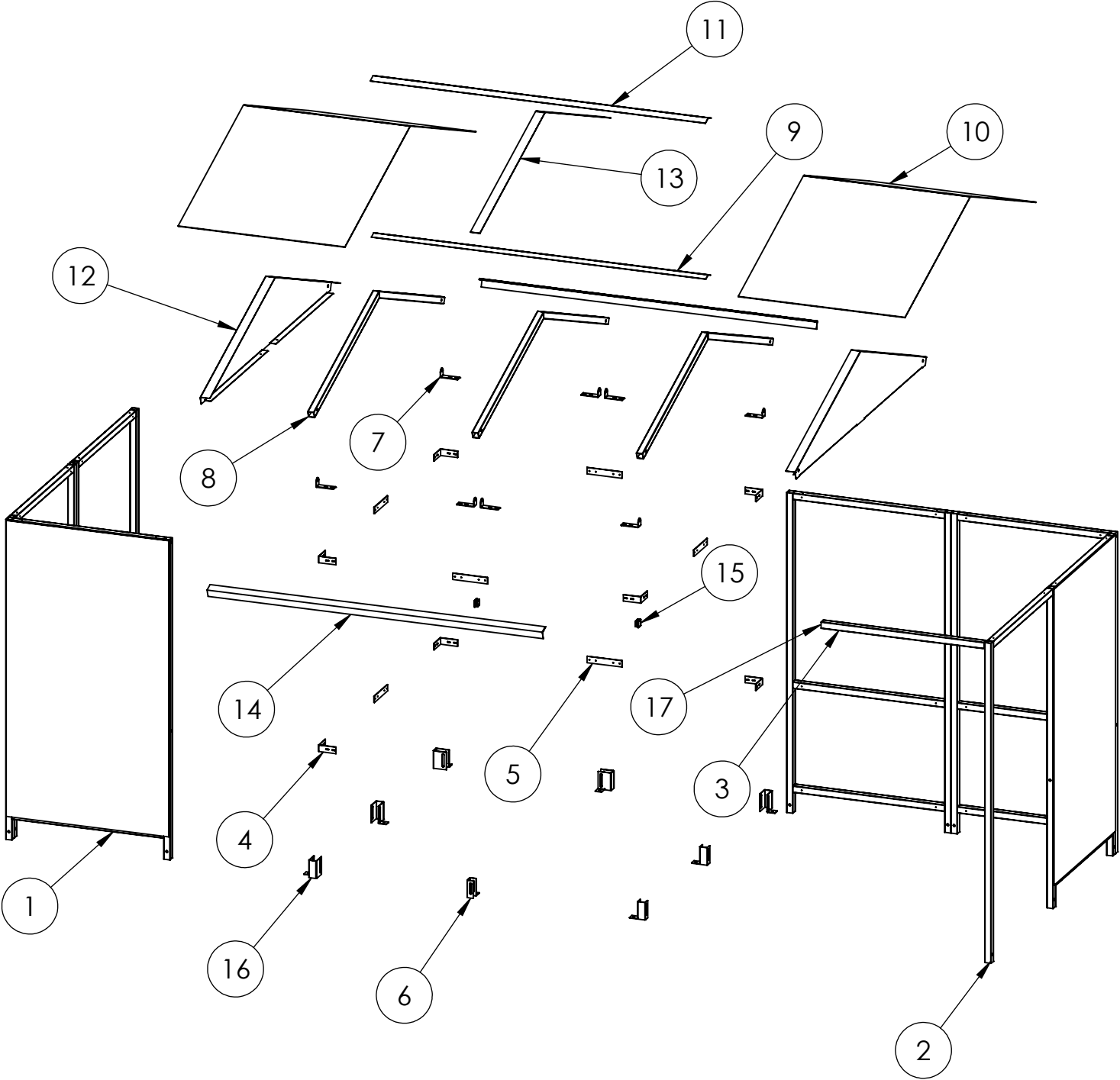

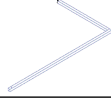

**Shelter type: SR8062-F**

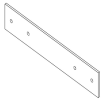
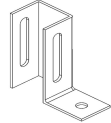
SR8062-F-01-011121-USA

# Exploded Parts

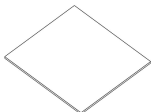

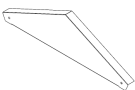
## PARTS LIST

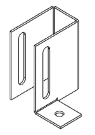
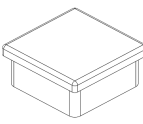
ITEM NO.	PART NUMBER	DRG NUMBER	Size (inch)	IMAGE	QTY.
1	S1C Frame	S1C	78.74 x 40.74		6
2	Post P1	P1	78.75 x 40.5		1
3	ST1 Roof Tie	ST1	40.35		1
4	CB1 Bracket - Slotted	CB1	4.3 x 4.3 x 1.57		7
5	JF1 Bracket	JF1	8.7 x 1.6		6
6	FT1 BRACKET	FT1	4.3 x 3.9 x 1.6		3
7	DR Bracket	DR	4.3 x 1.6 x 2		8
8	AR2R 2m Pitch Rafter	AR2R	85.75		3
9	AR2CLT2 2m Apex Roof centre lower trim 2m	AR2CLT2	82.85		1
10	AR2POA AR2 Roof Panel outer ALU	AR2POA	45.5 x 41.3		4
11	AR2CUT2 2m Apex Roof centre upper trim 2m	AR2CUT2	83		1
12	AR2IS 2m Pitch Infill Panel Shallow	AR2IS	85		2
13	AR2TS 2m Apex Roof Trim strip	AR2TS	45.5 x 2.3		2
14	ARFS2 Apex Roof F section 2m	ARFS2	83.1 x 2 x 2		2
16	FT3 Bracket	FT3	4.3 x 3.9 x 3.1		5
17	40x40 Plastic End Cap	EC40	1.6 x 1.6		3

# FIXINGS

Fittings	Bolt set M10			T25	T38		BTANCM12100
	M10 x 60mm	Nut	Washer	1" Tech screw	1.5" Tech screw	Black Caps	M10/12 x 100 mm Concrete Bolt
Pack A+B	33	33	66	136	40	66	11
Image							



Drill/Screwdriver

**Tools required:**



17mm Wrench



Mallet



T25 Torx bit

**Step 1** Assemble **S1C** frames to make up the main structure using **CB1** brackets for the corners and **JF1** brackets for the straight joints.

Please note 1.5" Tec Screws are for roof panels only

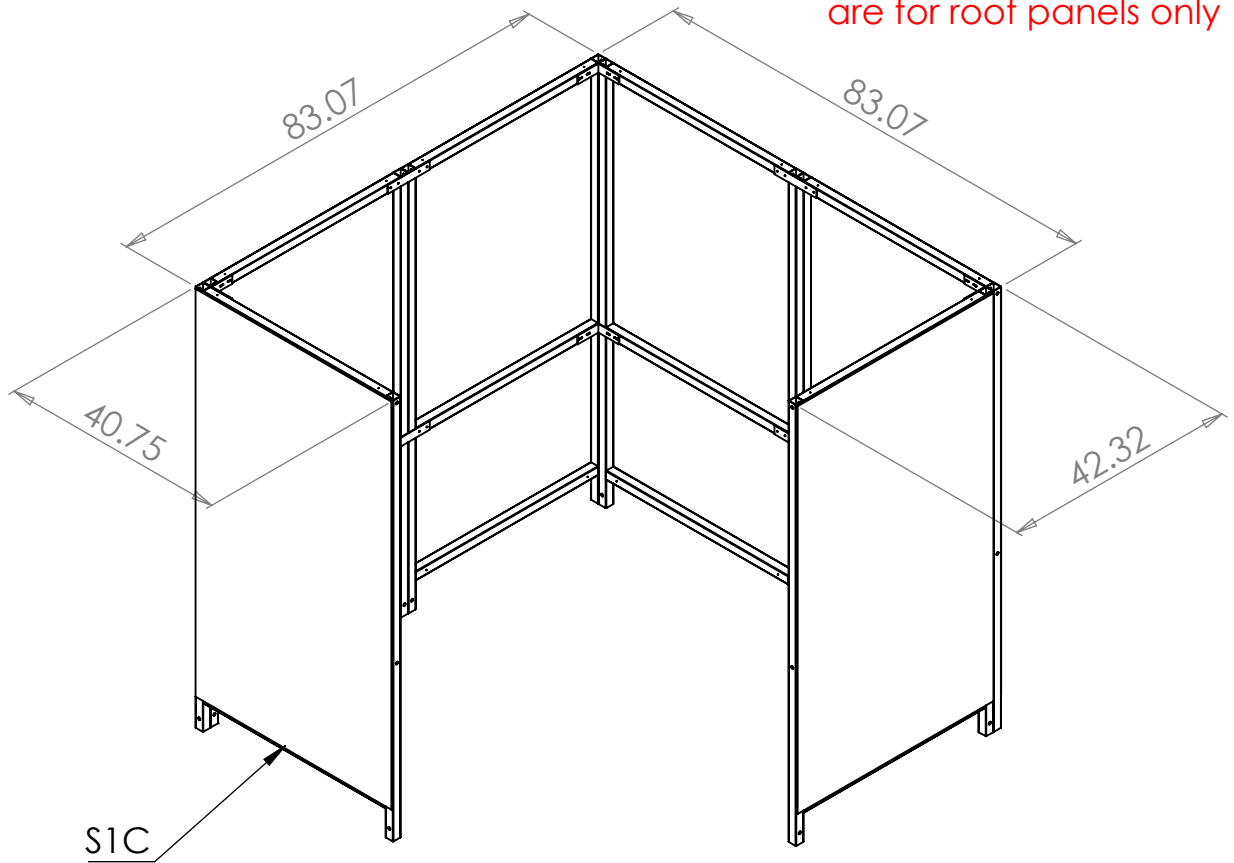

MEASURE THE WIDTH AND DEPTH OF THE SHELTER TO CHECK CORRECT ALIGNMENT.

Ensure correct alignment on all corners

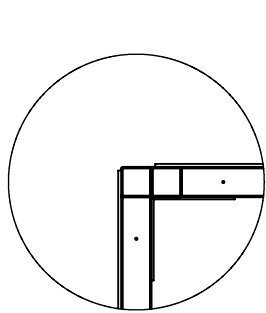

DETAIL A  
SCALE 1 : 10

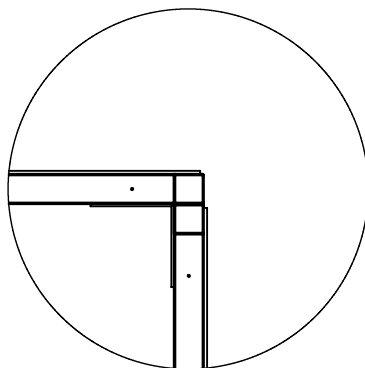

DETAIL B  
SCALE 1 : 10

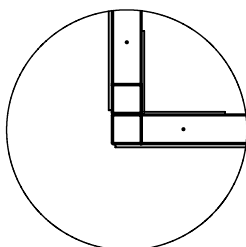

DETAIL C  
SCALE 1 : 10

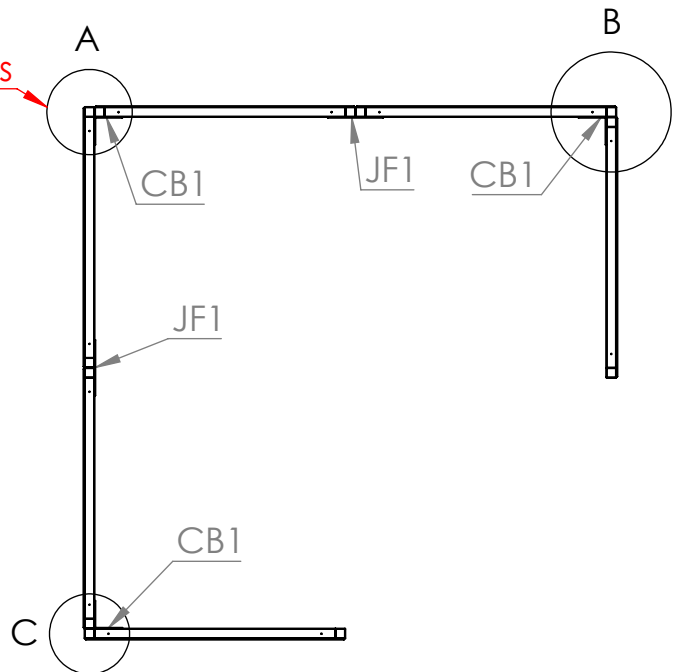

**Step 2** Use **JF1** and **CB1** brackets to attach the **P1** post and **ST1** Tie bar .

INSERT PLASTIC END CAPS (**EC40**)  
INTO **ST1** AND **P1**

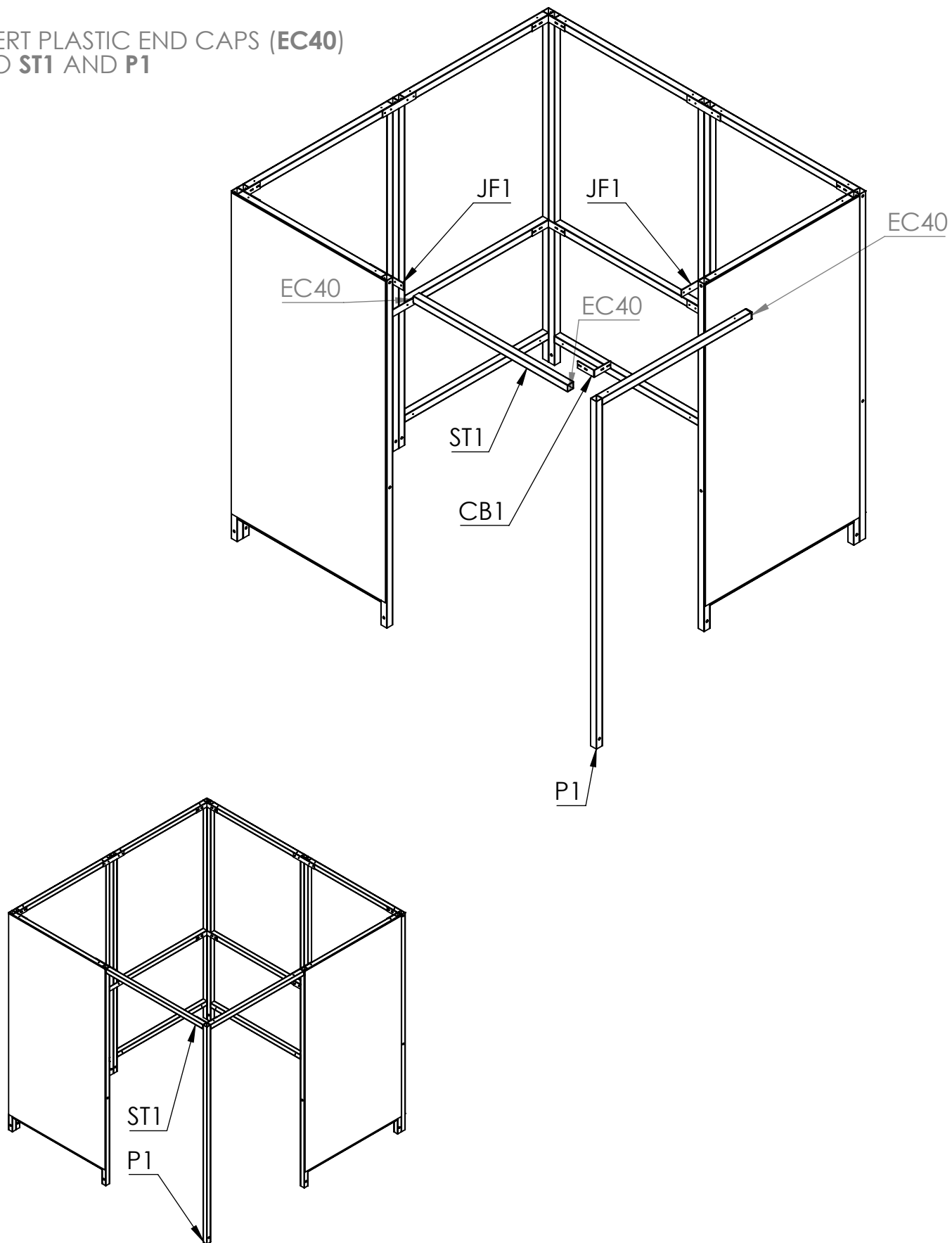

**Step 3** Attach **A2R2** rafters using **DR** brackets. Secure the **AR2IS** End Panels to **S1C** frames using 1" TECH Screws. The end rafters need to be placed in position at the same time as the **AR2IS**.

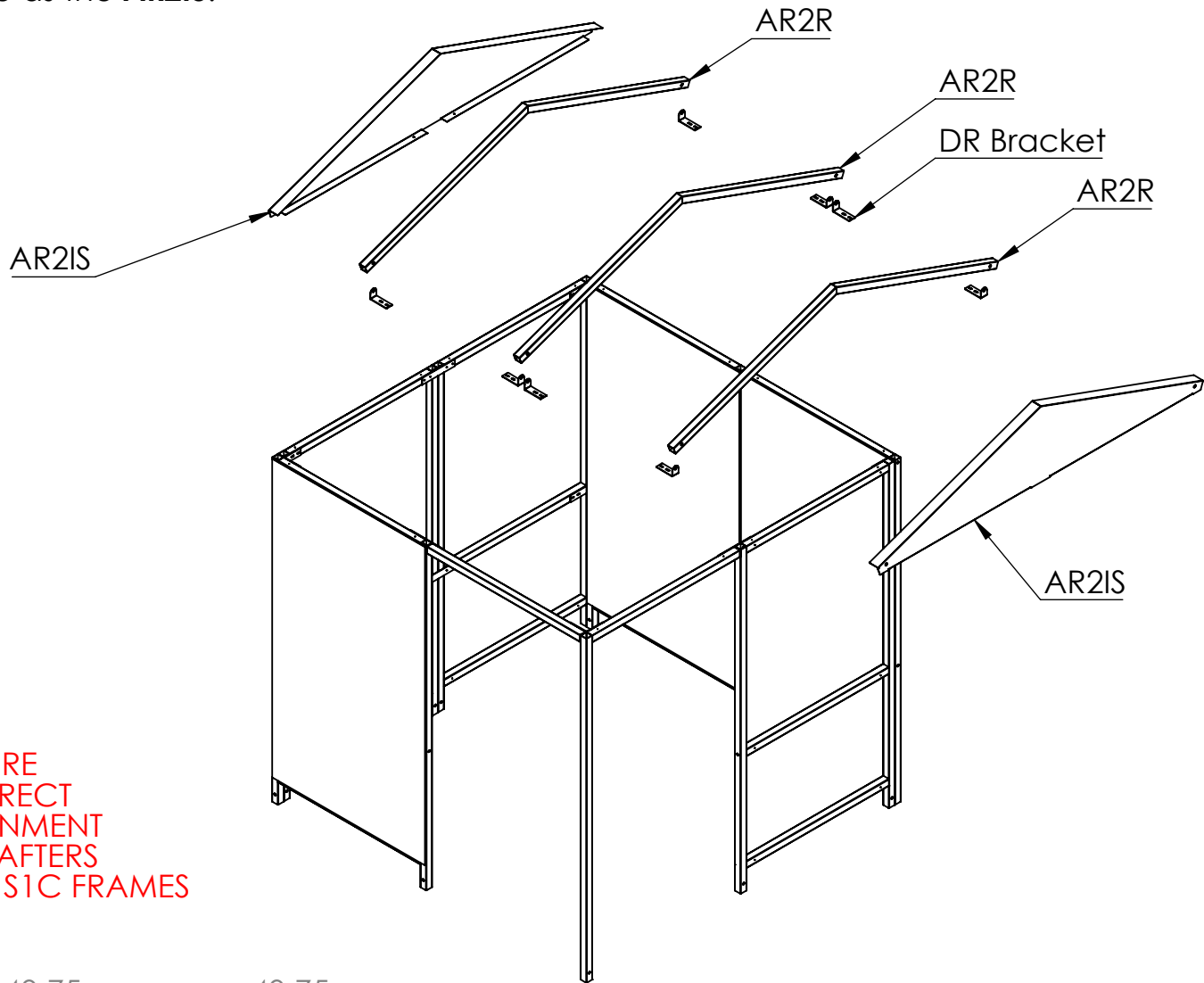

ENSURE  
CORRECT  
ALIGNMENT  
OF RAFTERS  
AND S1C FRAMES

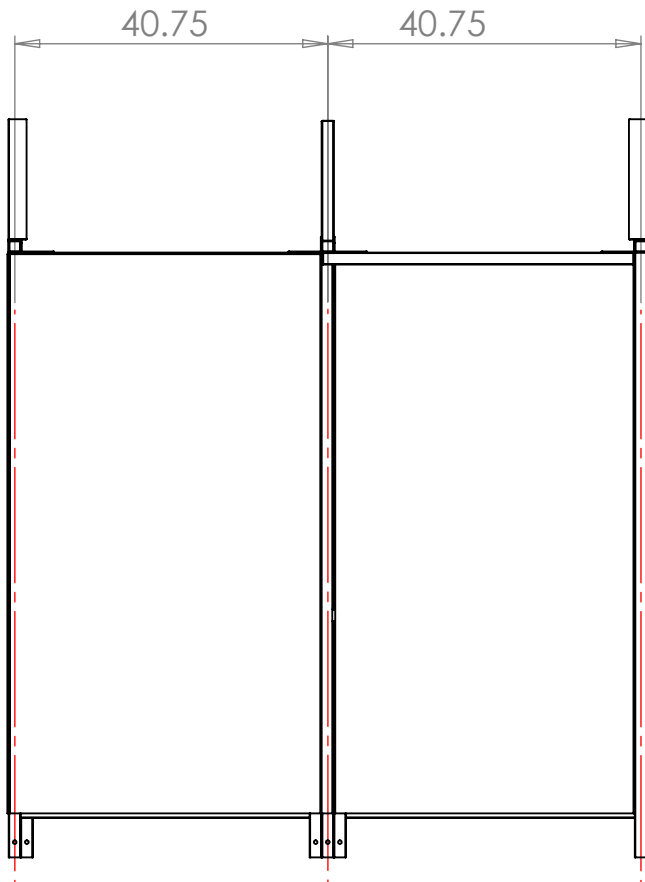

## Step 4

Attach the **AR2CLT2** to the top of the rafters. The **ARFS2** parts are to be attached to the lower part of the rafter as shown below.

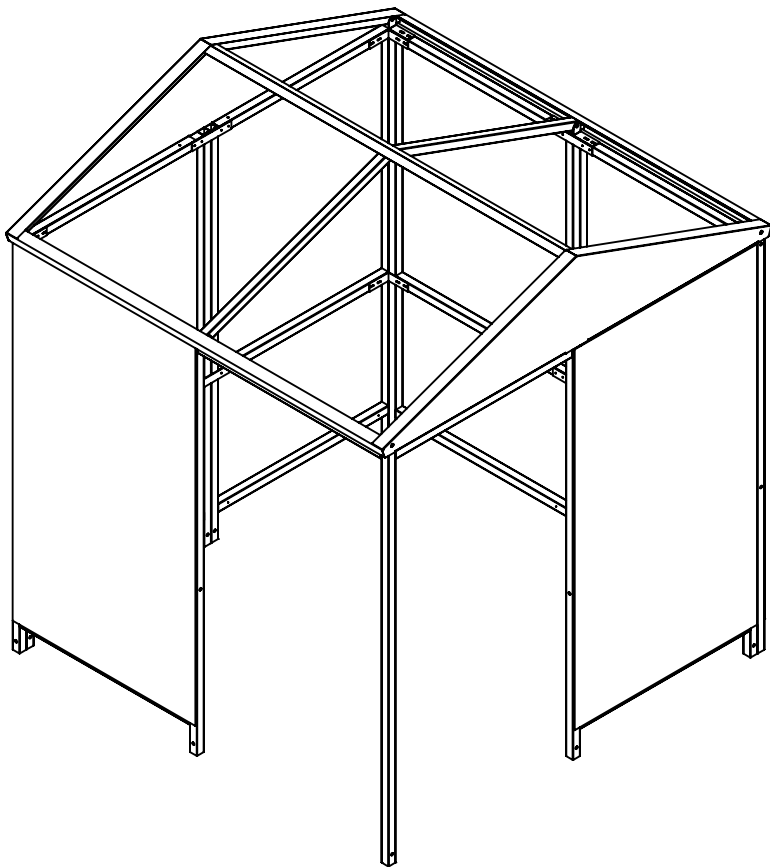
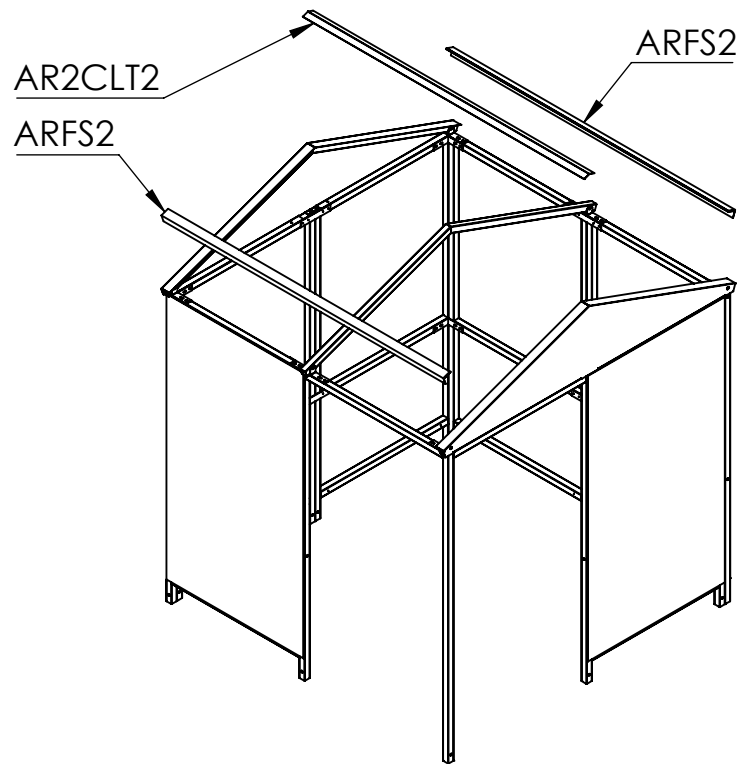



## Step 5

Align the outer roof panels **AR2POA** with the outer edges of the shelter. Use the **AR2TS** strips to seal the gap between the roof panels and cap off the top with the **AR2CUT2**. Once the shelter is in its final position it can be secured to the ground using **FT3** and **FT1** brackets and concrete bolts.

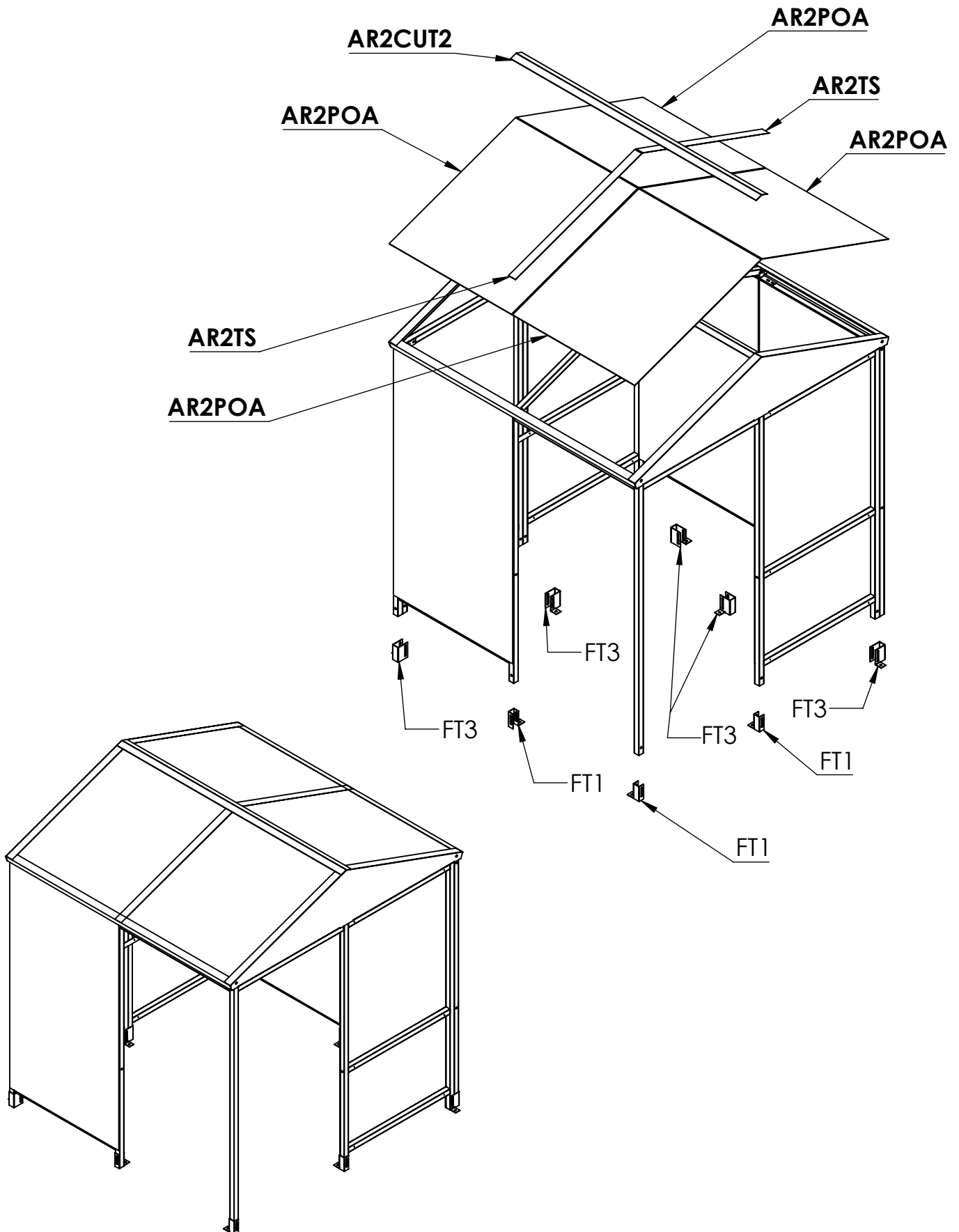

## PLAN VIEW

OVERALL DIMENSIONS AND GROUND FIXING POSITIONS  
Suggested size for concrete base: 8" oversized on all 4 sides.

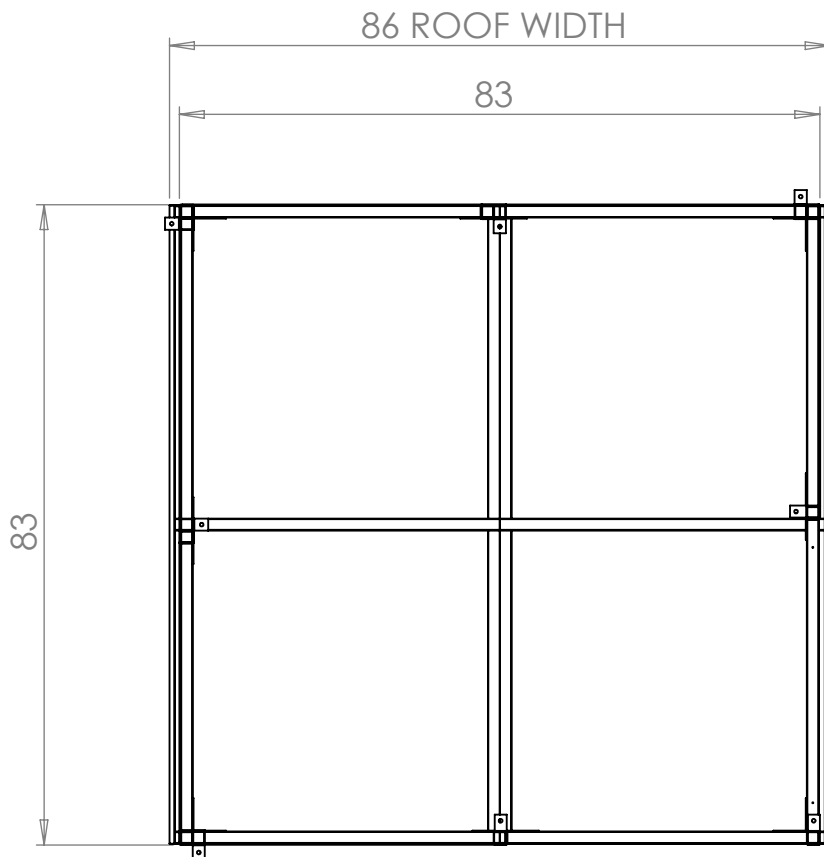

# THANK YOU FOR PURCHASING THIS PRODUCT

## MAINTENANCE:

To ensure your products give you many years of use we recommend that you:

- Clean panels regularly with soapy water
- Ensure all fittings are tight (for example after a big storm)
- Touch up any exposed metal should it get scratched

## CONTACT DETAILS:

Email : Sales@nobutts.com

Web : www.nobutts.com

Tel : 10888-662-8887

No Butts Bin Company, Inc. 16 Birch lane, Madison, CT 06443

<b>All Parts and Fixings checked by:</b>	
Print Name:	Signature: