

Assembly Instructions

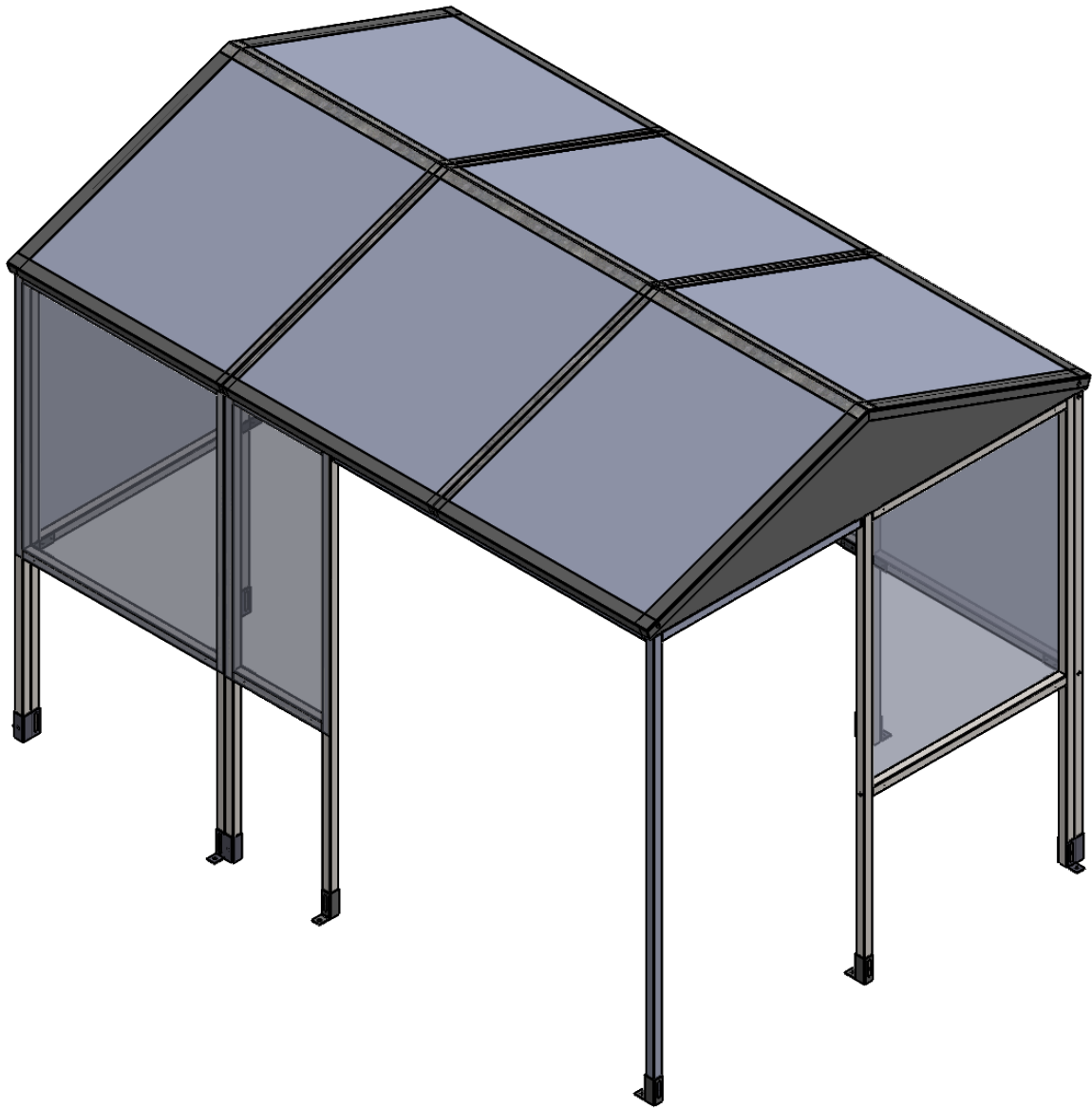

Email : sales@nobutts.com
Web : www.nobutts.com
Tel : 1-888-662-8887







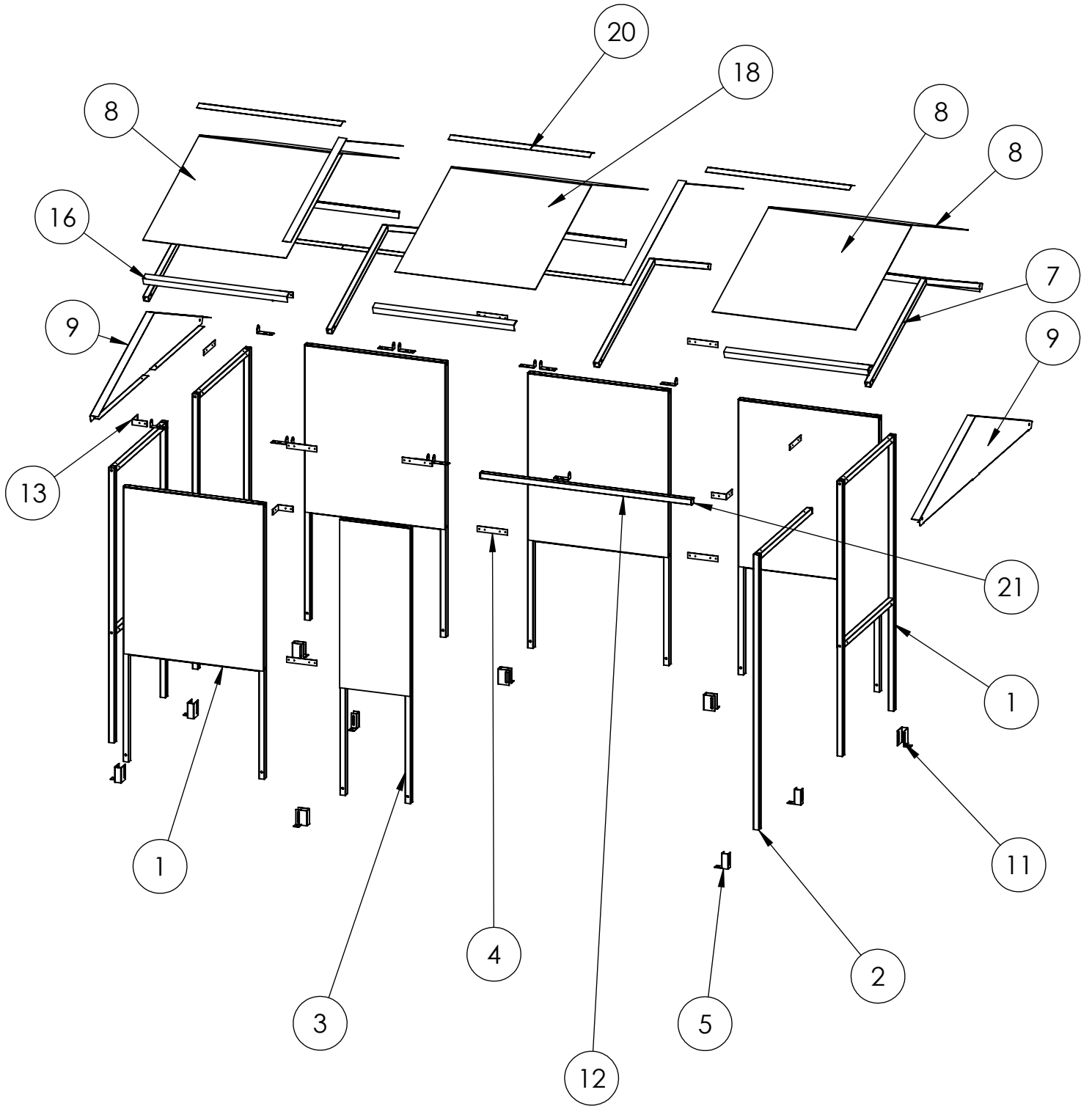







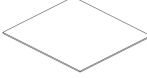
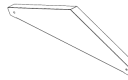

Shelter type: SR8063

SR8063-01-02112021-USA

Exploded View

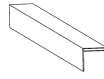
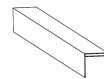
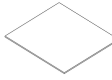

PARTS LIST

ITEM NO.	PART NUMBER	DRG number	Size (inch)	IMAGE	QTY.
1	S1 Frame	SC1	78.74 x 40.74		7
2	Post P1	P1	78.75 x 40.5		1
3	S3C Frame	S3			1
4	JF1 Bracket	JF1	8.7 x 1.6		10
5	FT1 BRACKET	FT1	4.3 x 3.9 x 1.6		3
6	DR Bracket	DR	4.3 x 1.6 x 2		12
7	AR2R 2m Pitch Rafter	AR2R	85.75		4
8	AR2POA AR2 Roof Panel outer ALU	AR2POA	45.5 x 41.3		4
9	AR2IS 2m Pitch Infill Panel Shallow	AR2IS	85		2
10	AR2TS 2m Apex Roof Trim strip	AR2TS	45.5 x 2.3		4
11	FT3 Bracket	FT3	4.3 x 3.9 x 3.1		7
12	ST5 Roof Tie	ST5	60.75		1
13	CB1 Bracket	CB1	4.3 x 4.3 x 1.6		7
14	Roof centre lower trim outer	AR2CLTO-03	41.4		2
15	Roof centre lower trim inner	AR2CLTI-02	40.74		1
16	Roof F Section Outer	ARFSO	41.5		4
17	ARFSI Apex Roof F Section Inner	ARFSI	40.75		2
18	AR2PIA AR2 Roof Panel inner ALU	AR2PIA	45.5 x 40.5		2
19	Roof centre upper trim outer	AR2CUTO-02	41.5		2
20	Roof centre upper trim inner	AR2CUTI	40.75		1
21	40x40 Plastic End Cap	EC40	1.6 x 1.6		3

FIXINGS

Fittings	Bolt set M10			T25	T38		BTANCM12100
	M10 x 60mm	Nut	Washer	1" Tech screw	1.5" Tech screw	Black Caps	M10/12 x 100 mm Concrete Bolt
Pack A+B	33	33	66	136	40	66	11
Image							



Drill/Screwdriver

Tools required:



17mm Wrench



Mallet



T25 Torx bit

Step 1 Assemble **S1C** frames to make up the main structure using **CB1** brackets for the corners and **JF1** brackets for the straight joints.

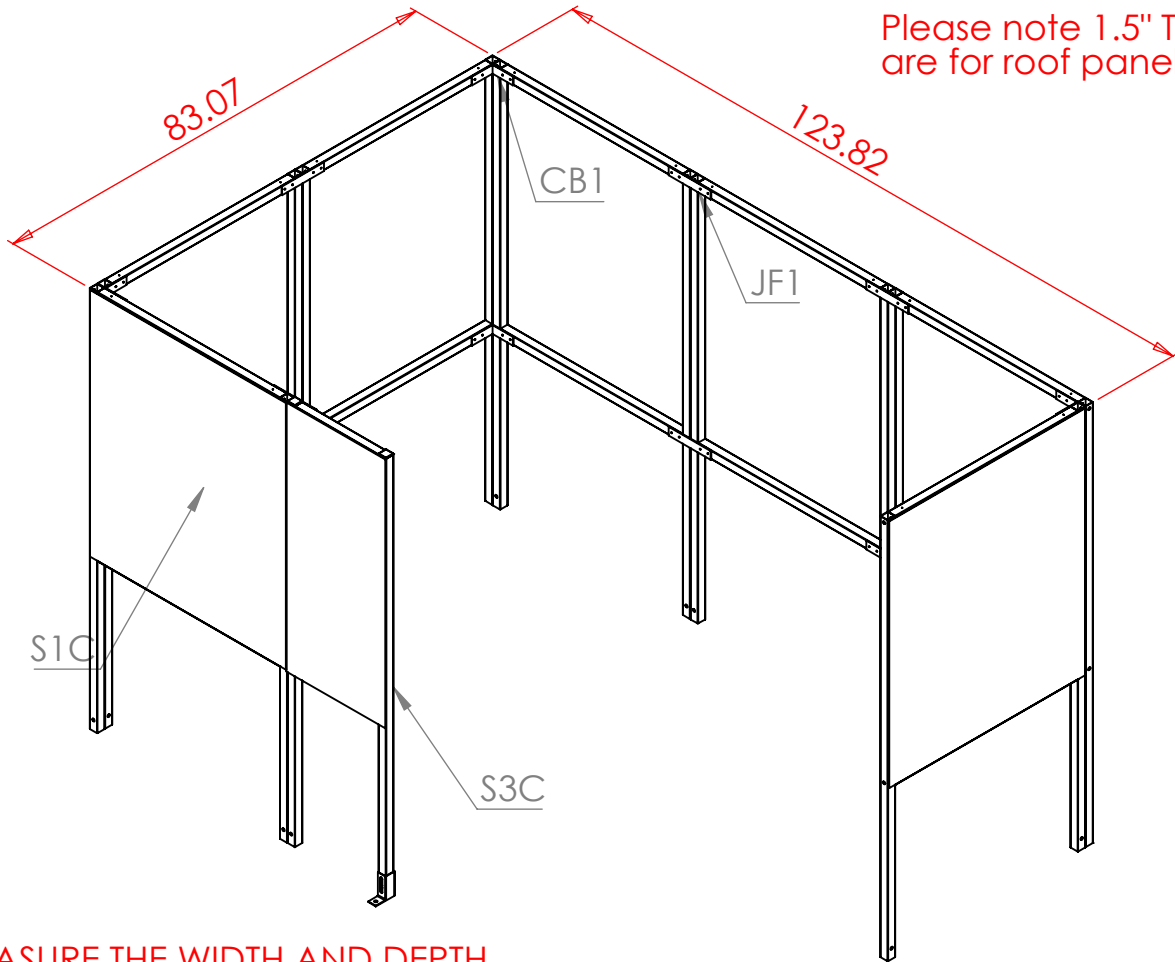

MEASURE THE WIDTH AND DEPTH OF THE SHELTER TO CHECK CORRECT ALIGNMENT.

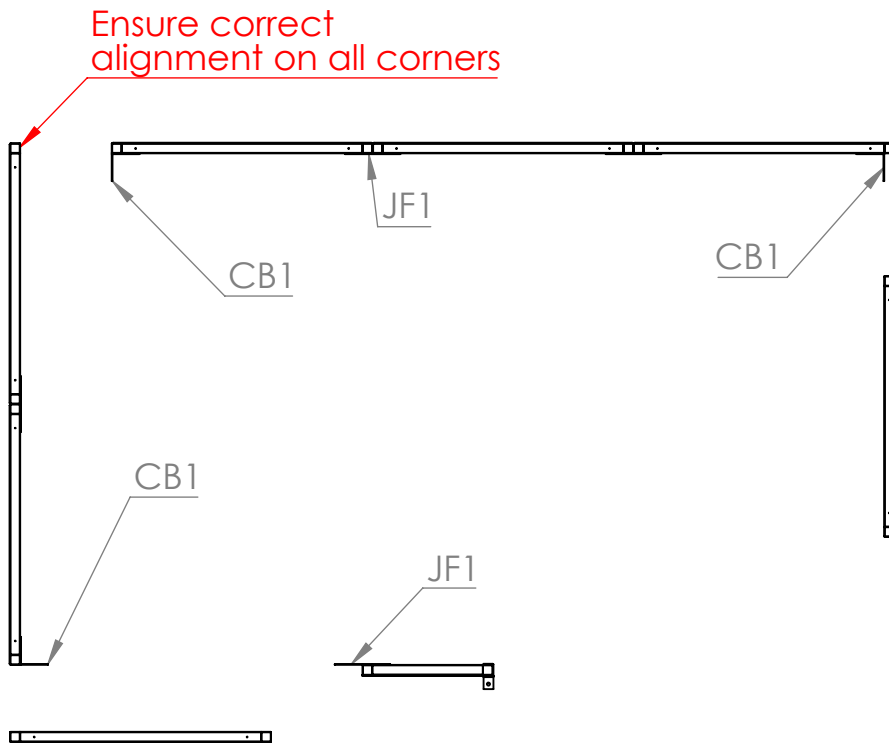

Step 2 Use **JF1** and **CB1** brackets to attach the **P1** post and **ST5** Tie bar .

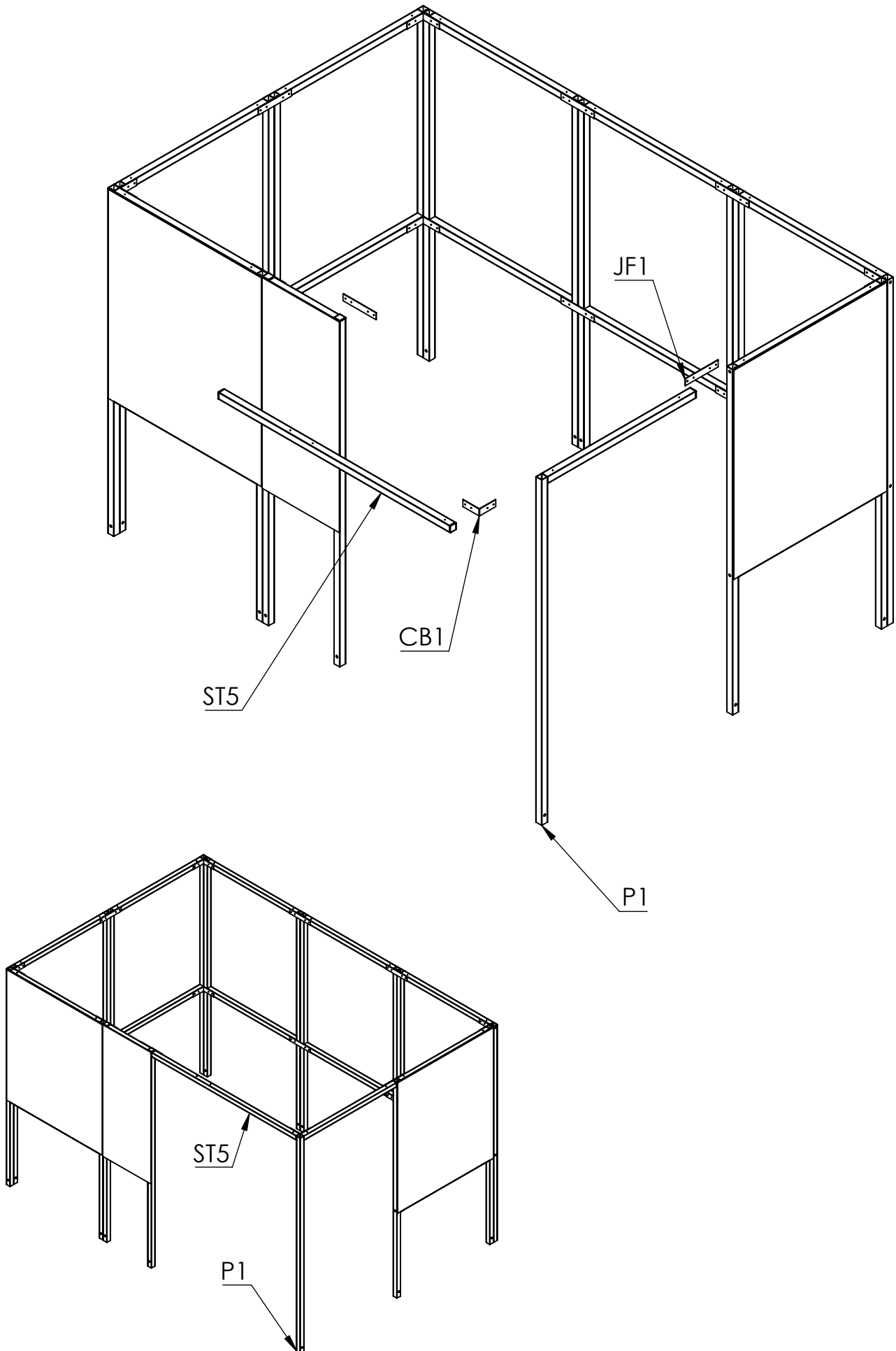

Step 3 Attach **A2R2** rafters using **DR** brackets. Secure the End Panels to the frames using 1" Tech Screws. The end rafters need to be placed in position at the same time as the **AR2IS**.

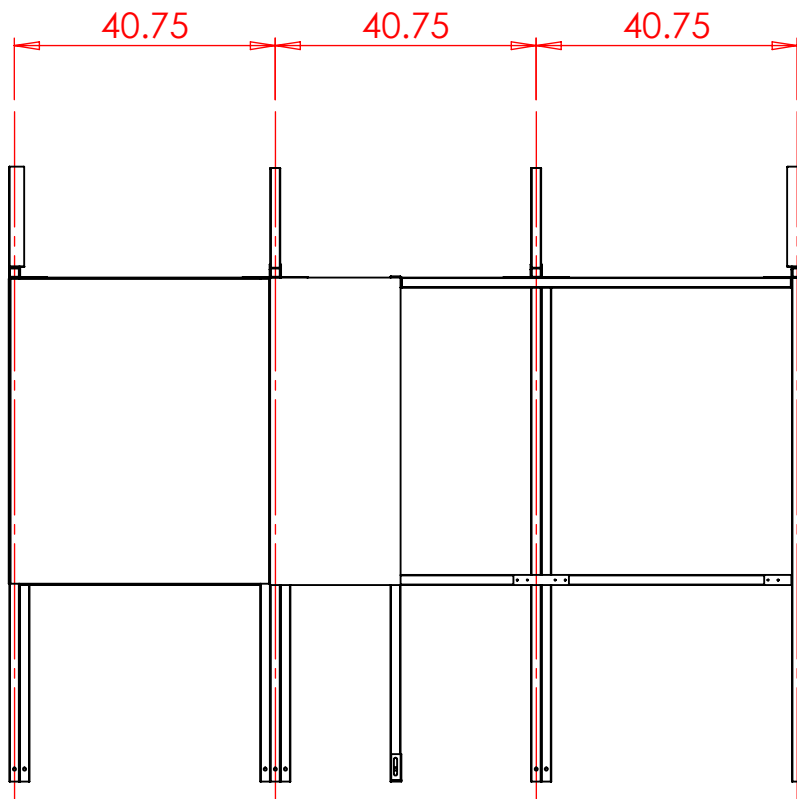
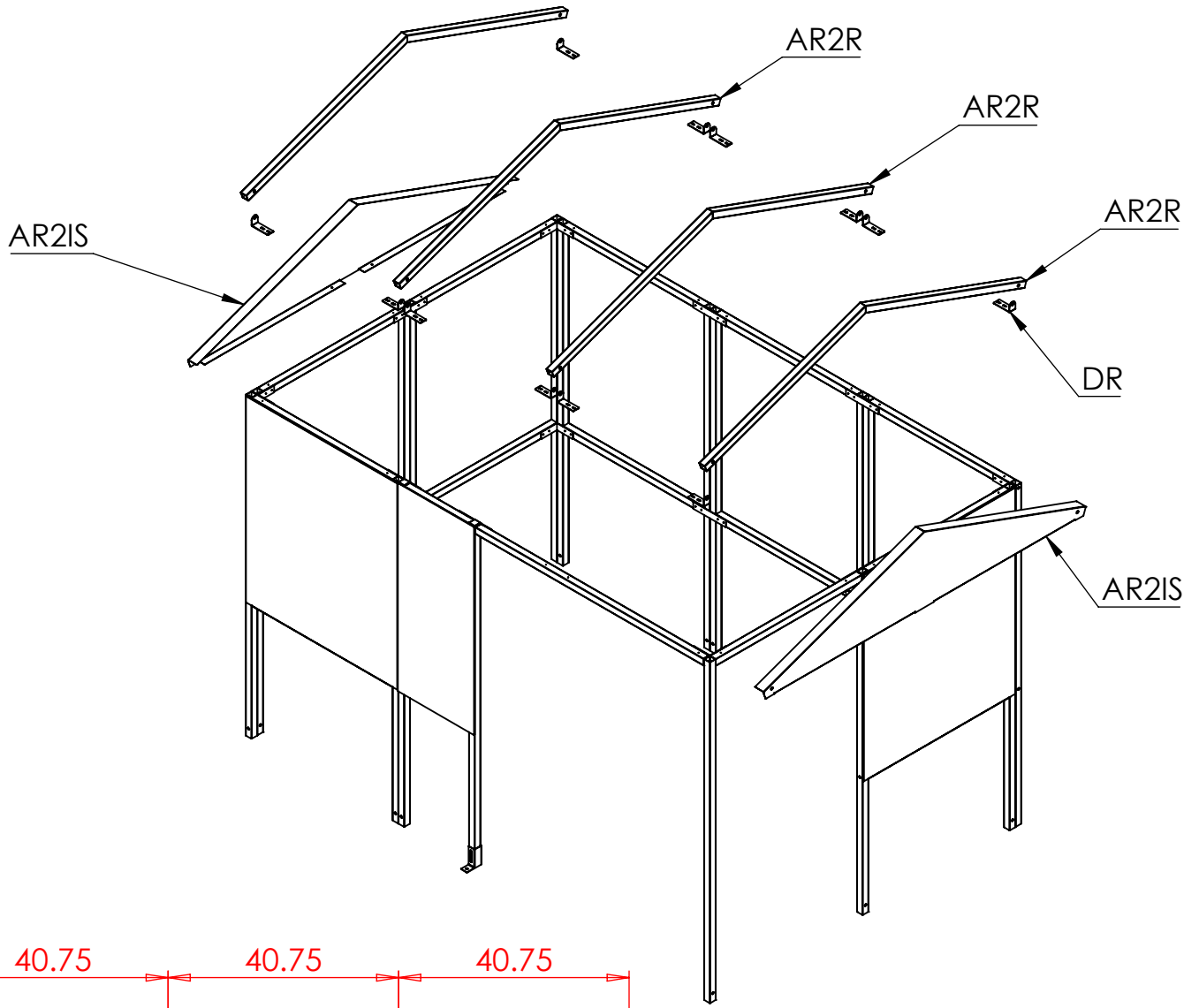

FRONT VIEW

Step 4 Attach the **AR2CLTI** and **AR2CLTO** to the top of the rafters. The **ARFSI** and **ARFSO** parts are to be attached to the lower part of the rafter as shown below.

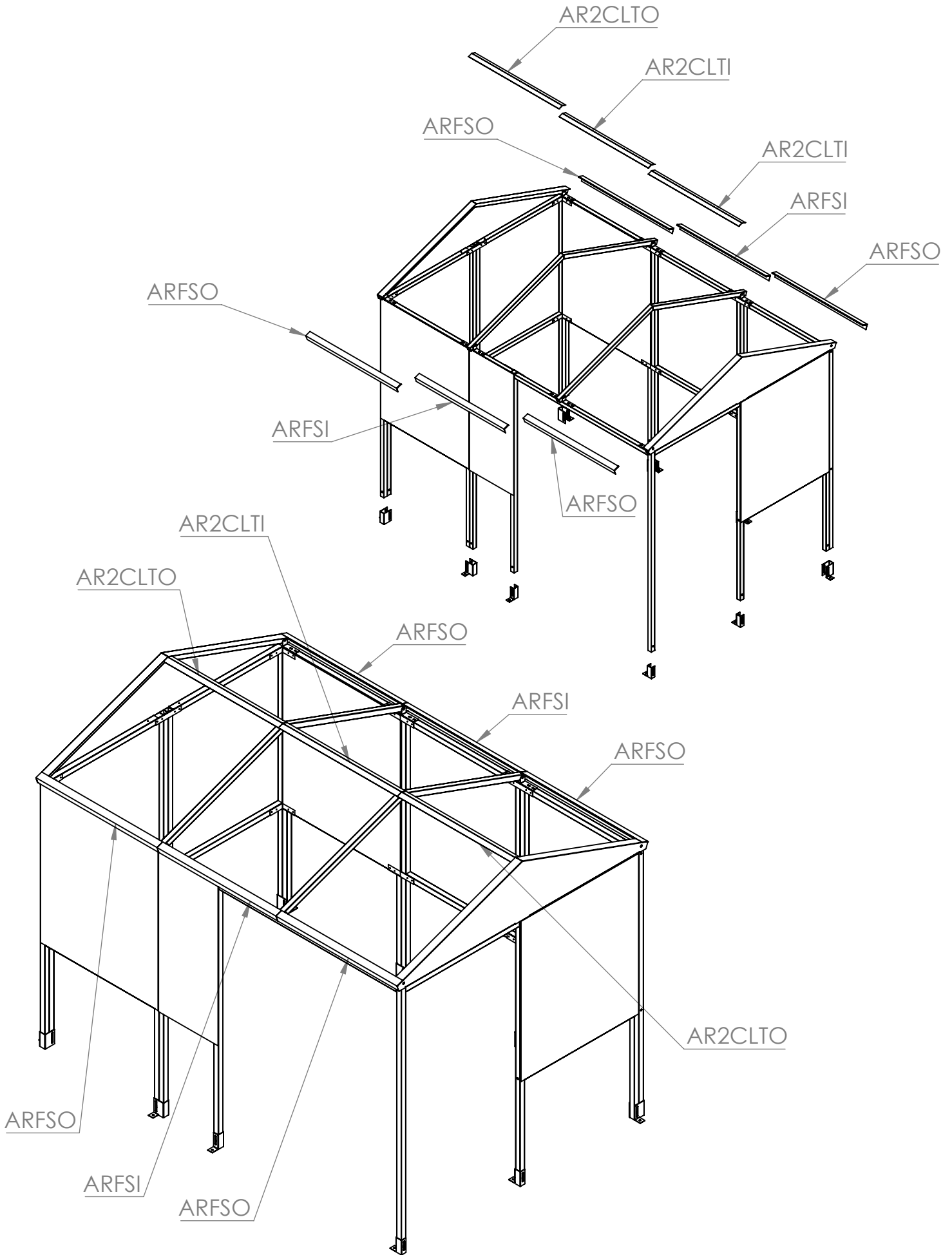

Step 5

Align the outer roof panels **AR2POA** with the outer edges of the shelter and space the **AR2POI** panels central. Use the **AR2TS** strips to seal the gap between the roof panels and cap off the top with the **AR2CUTO/AR2CUTI**. Once the shelter is in the final position it can be secured to the ground using **FT3** and **FT1** brackets and the concrete bolts.

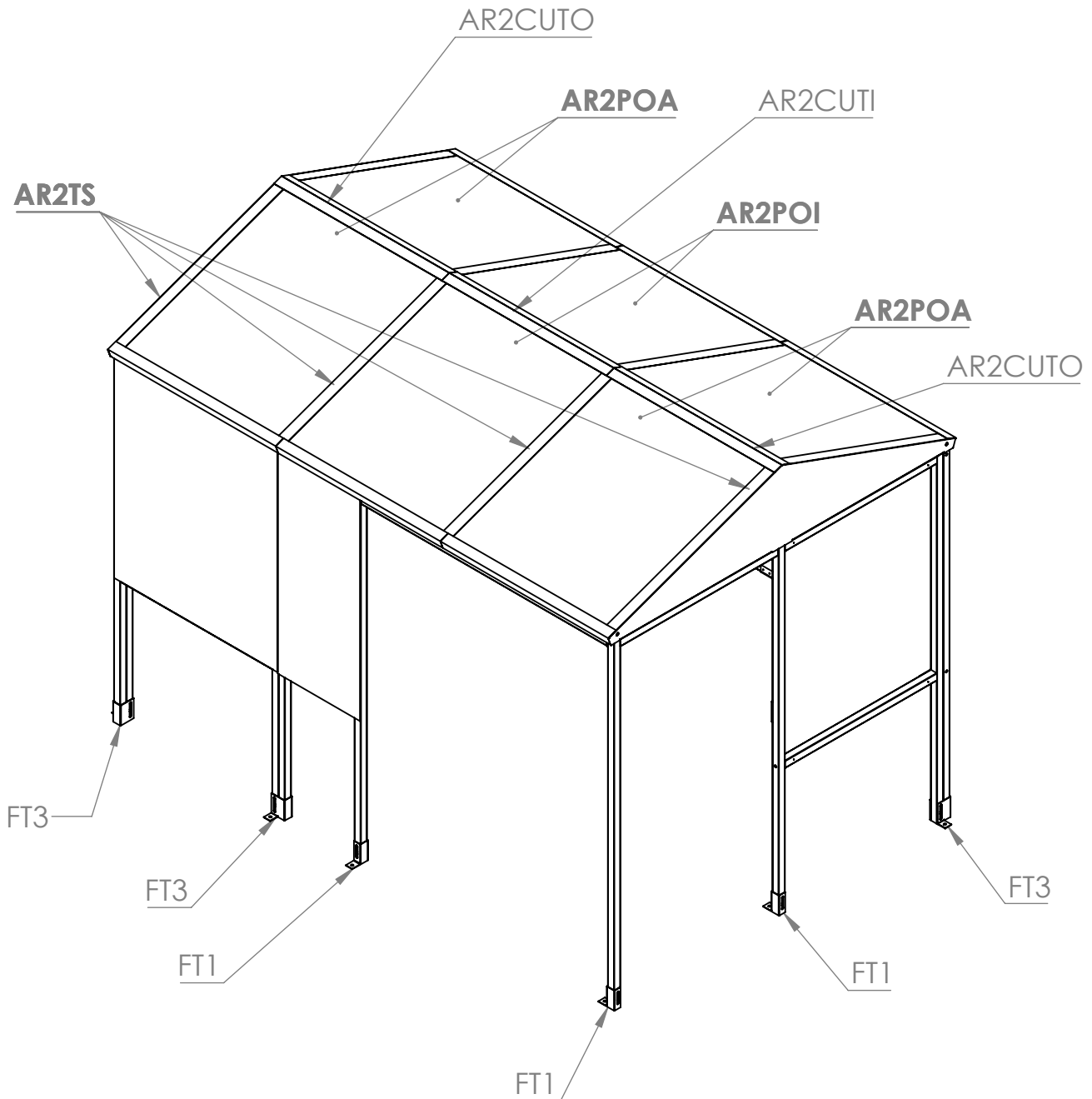

PLAN VIEW

OVERALL DIMENSIONS AND GROUND FIXING POSITIONS
Suggested size for concrete base: 8" oversized on all 4 sides.

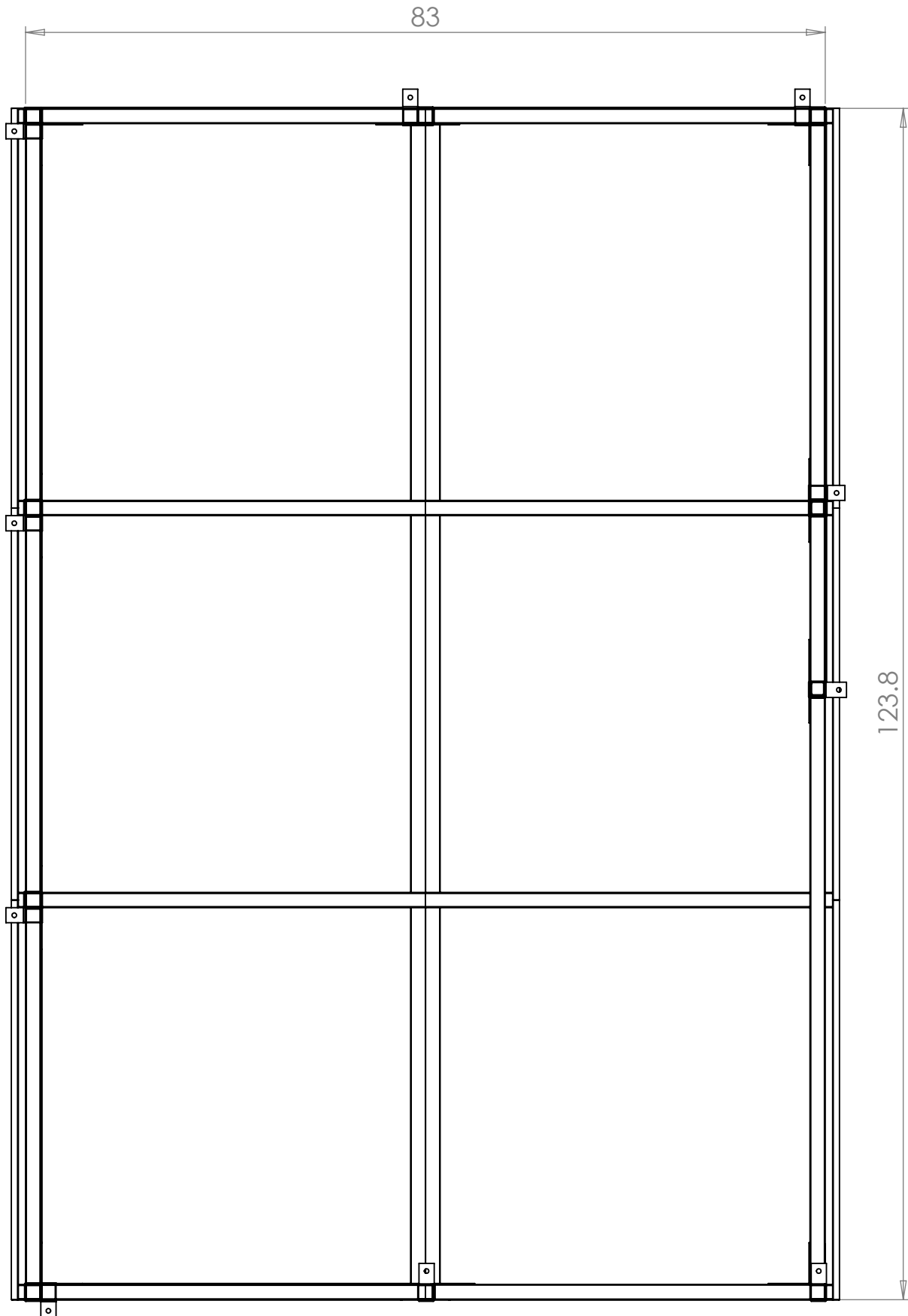

THANK YOU FOR PURCHASING THIS PRODUCT

MAINTENANCE:

To ensure your products give you many years of use we recommend that you:

- Clean panels regularly with soapy water
- Ensure all fittings are tight (for example after a big storm)
- Touch up any exposed metal should it get scratched

CONTACT DETAILS:

Email : Sales@nobutts.com

Web : www.nobutts.com

Tel : 10888-662-8887

No Butts Bin Company, Inc. 16 Birch lane, Madison, CT 06443

All Parts and Fixings checked by:	
Print Name:	Signature: