

Assembly Instructions

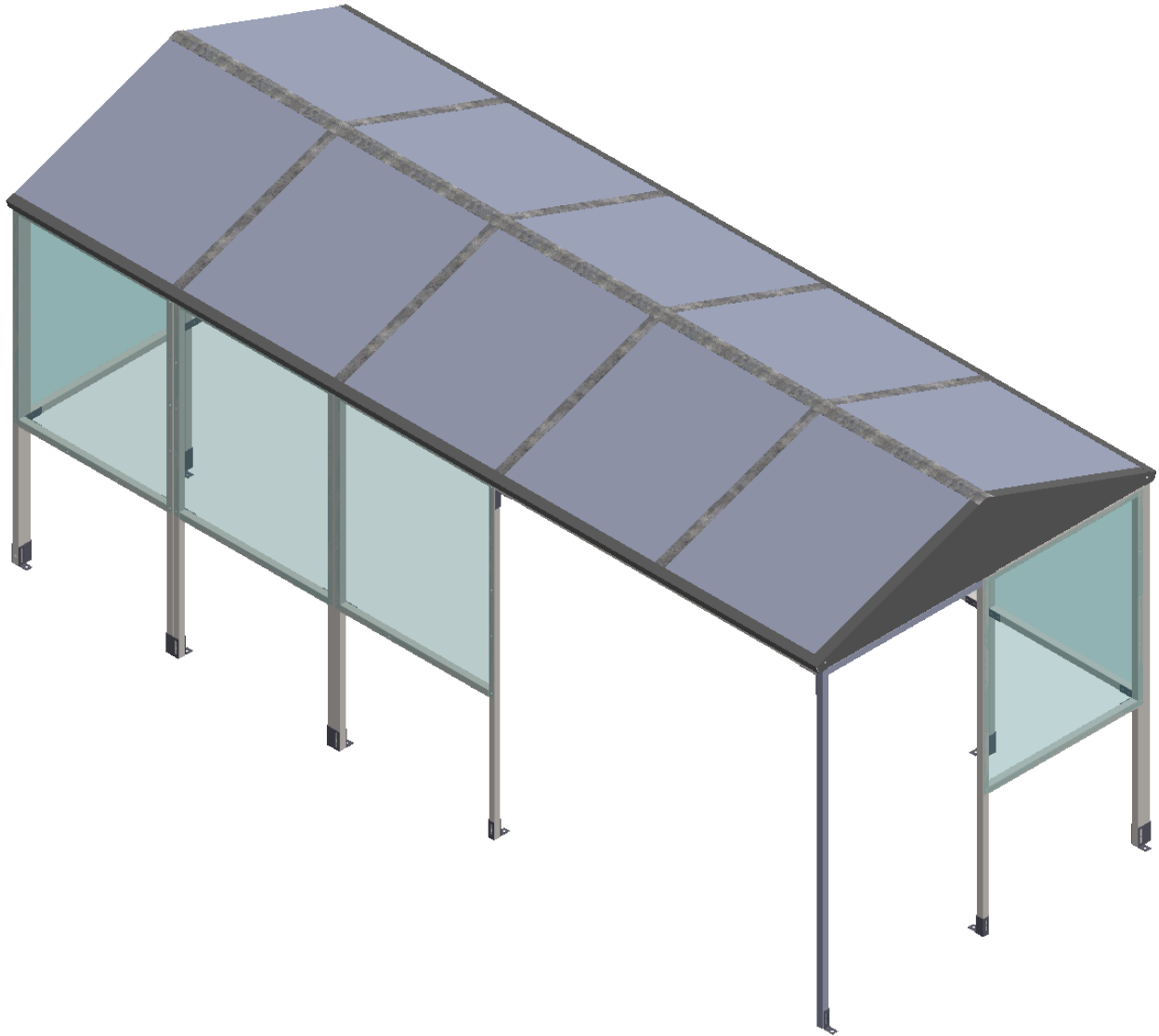

No Butts Bin Co.
Better Ash & Trash Solutions
Est. 1991

Email : Sales@nobutts.com

Web : www.nobutts.com

Tel : 1-888-662-8887

Shelter type: SR8065

SR8065-01-03112021-USA

Exploded View

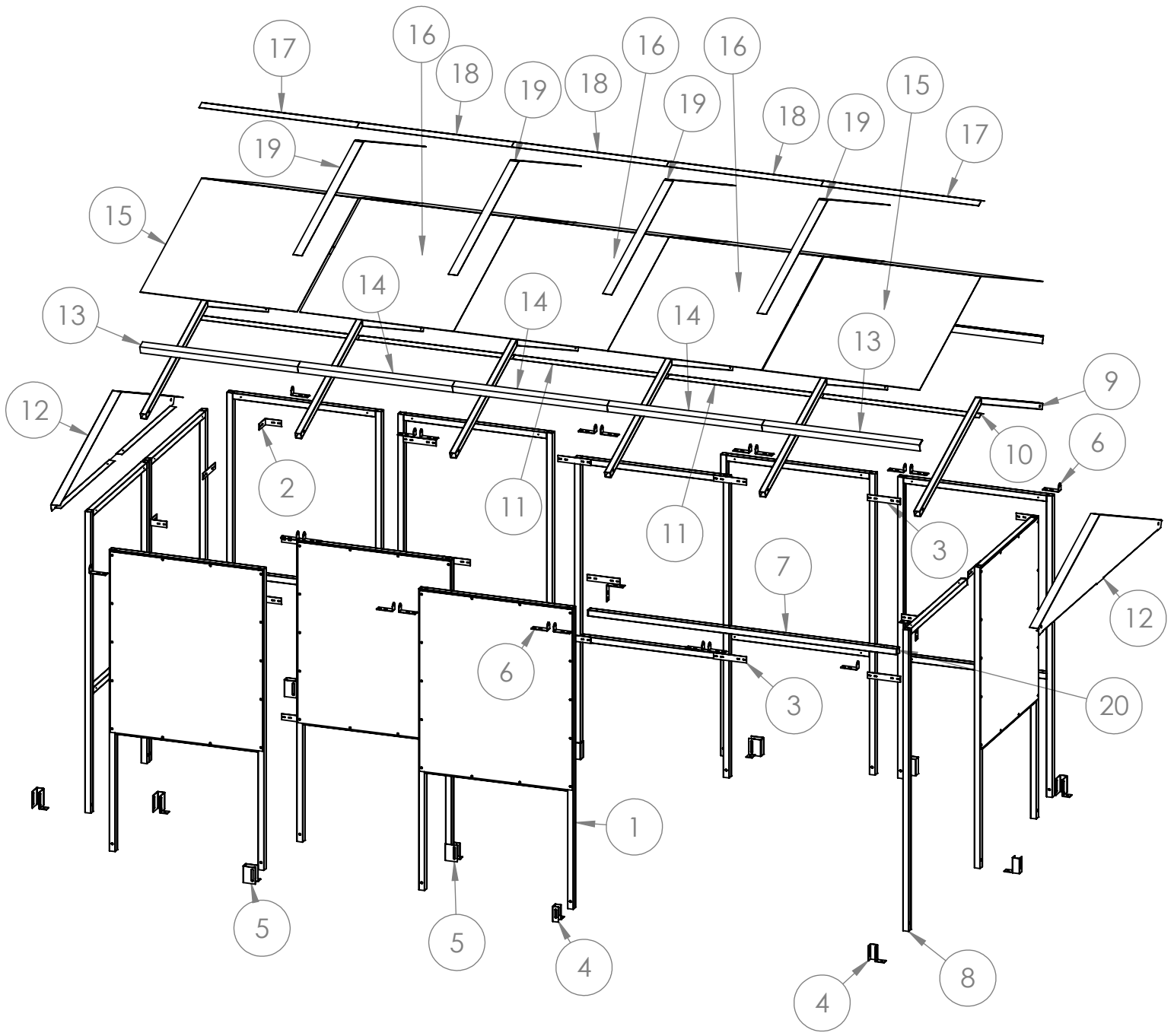

Tools required:



Drill/Screwdriver



Wrench











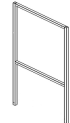

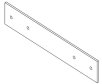



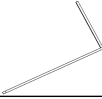

Mallet



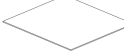



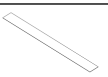
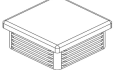

Torx bit

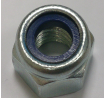
PARTS LIST

ITEM NO.	PART NAME	DRG NUMBER	Size (inch)	IMAGE	QTY.
1	S1 Frame	S1	78.74 x 40.74		11
2	CB1 Bracket	CB1	4.3 x 4.3 x 1.57		9
3	JF1 Bracket	JF1	4.33 x 1.57		16
4	FT1 Bracket	FT1	1.57 x 1.57 x 3.94		3
5	FT3 Bracket	FT3	1.57 x 3.15 x 4.17		10
6	DR Bracket	DR	4.3 x 1.6 x 2		20
7	ST3 Roof Tie	ST3	81.1		1
8	Post P1	P1	78.75 x 40.5		1
9	AR2R 2m Pitch Rafter	AR2R-02	85.75		6
10	Roof centre lower trim outer	AR2CLTO-03	41.4		2
11	Roof centre lower trim inner	AR2CLTI-02	40.74		3
12	AR2IS 2m Pitch Infill Panel Shallow	AR2IS-02	85		2
13	Roof F Section Outer	ARFSO	41.5		4
14	ARFSI Apex Roof F Section Inner	ARFSI	40.75		6
15	AR2POA AR2 Roof Panel outer ALU	AR2POA	45.5 x 41.3		4
16	AR2PIA AR2 Roof Panel inner ALU	AR2PIA	45.5 x 40.5		6
17	Roof centre upper trim outer	AR2CUTO-02	41.5		2
18	Roof centre upper trim inner	AR2CUTI	40.75		3
19	AR2TS 2m Apex Roof Trim strip	AR2TS-01	45.5 x 2.3		8
20	40x40 Plastic End Cap	EC40	1.6 x 1.6		2

FIXINGS

Fittings	Bolt set M10			T25	T38		BTANCM12100
	M10 x 60mm	Nut	Washer	1" Tech screw	1.5" Tech screw	Black Caps	M10/12 x 100 mm Concrete Bolt
Pack A+B	33	33	66	136	40	66	11
Image							

Step 1 Assemble **S1** frames to make up the main structure using **CB1** brackets for the Corners and **JF1** brackets for the straight joints.

Please note 1.5" Tec Screws are for roof panels only

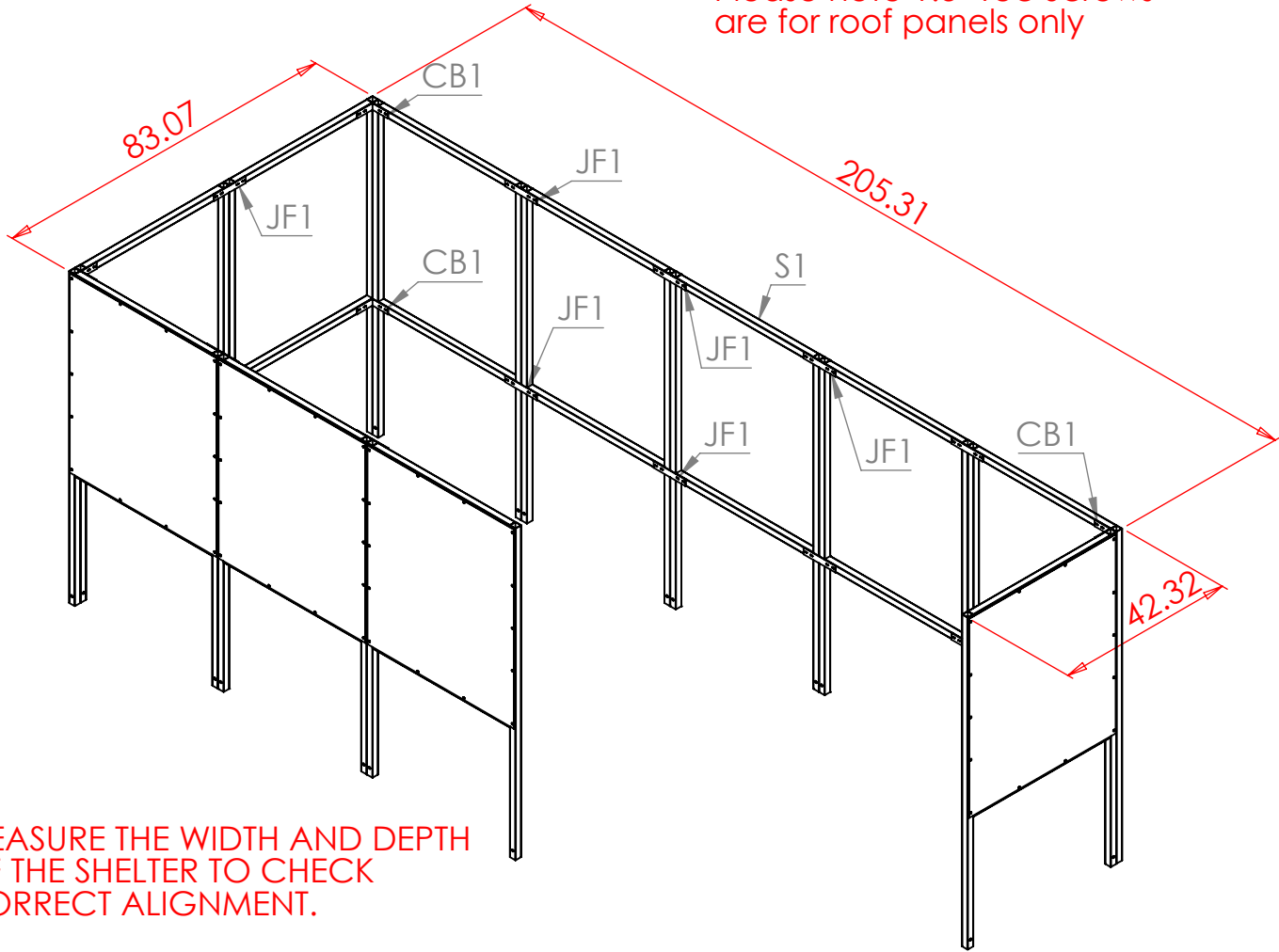

MEASURE THE WIDTH AND DEPTH OF THE SHELTER TO CHECK CORRECT ALIGNMENT.

Ensure correct alignment on all corners

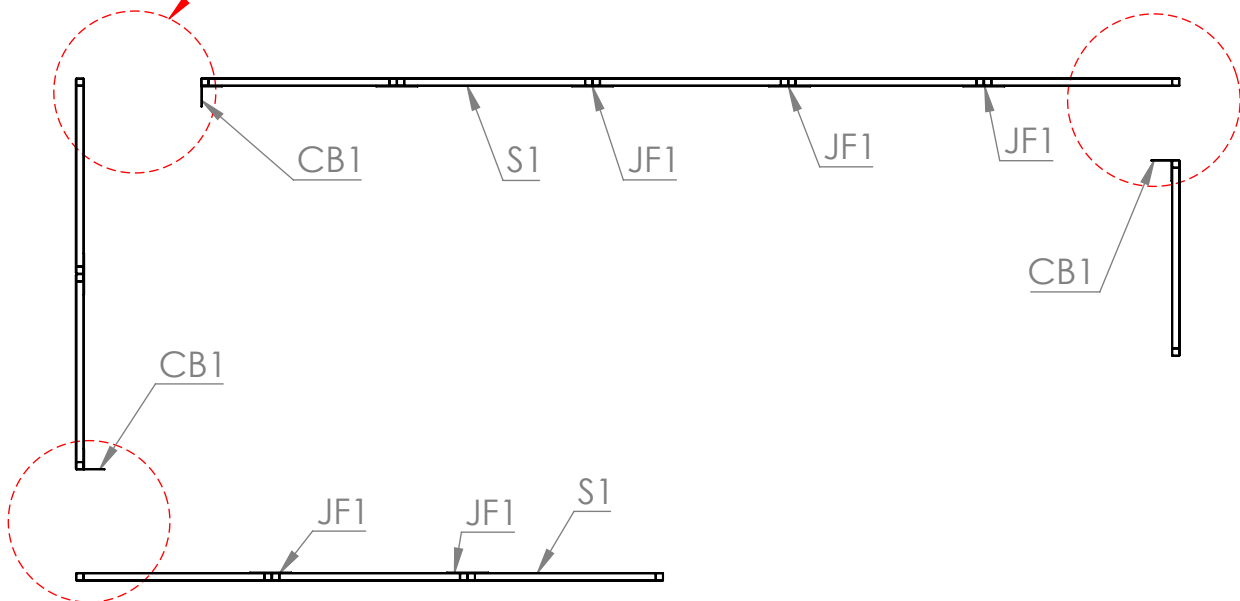

Step 2 Use **JF1** and **CB1** brackets to attach the **P1** post and **ST3** Tie bar.

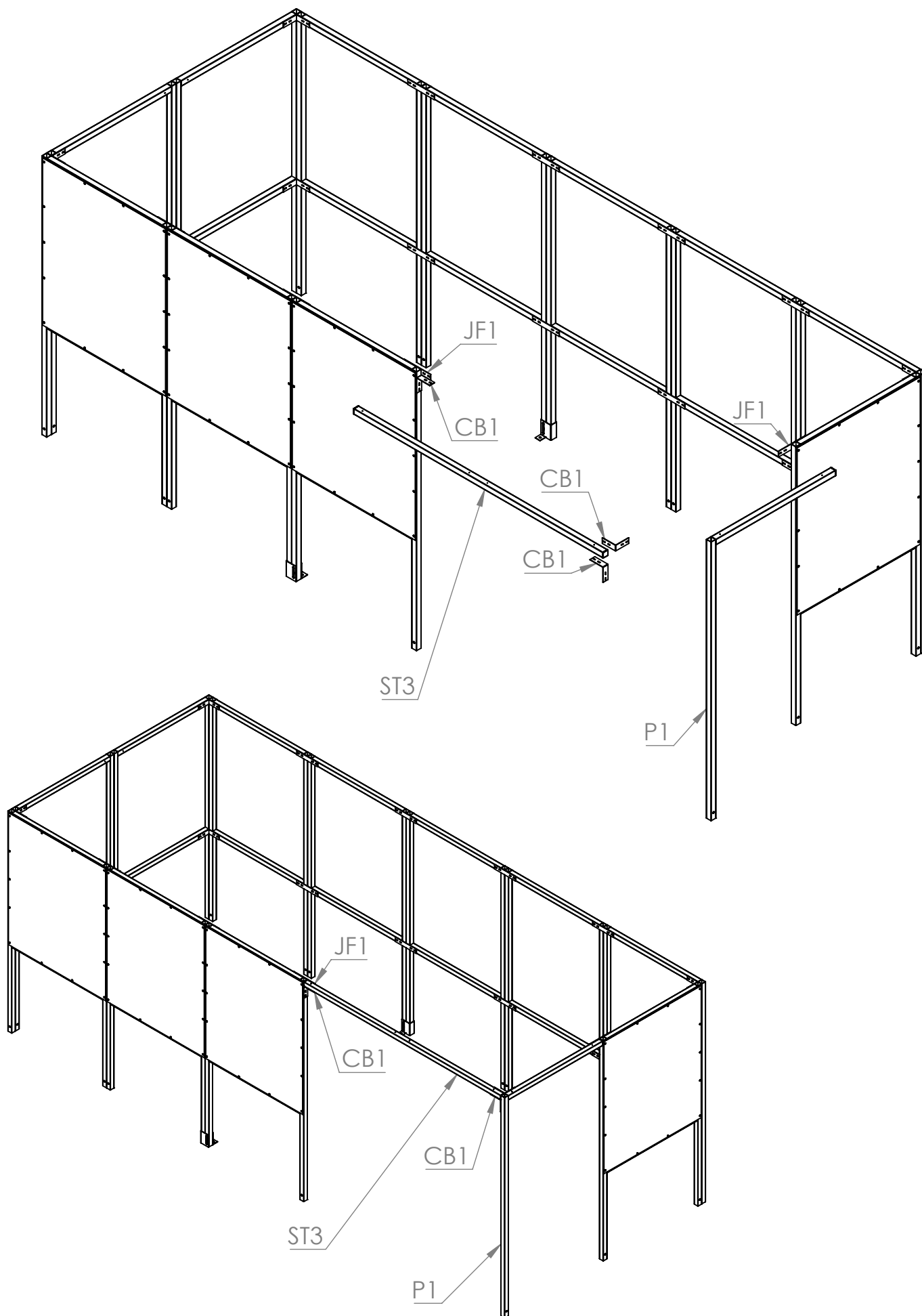

Step 3 Attach **AR2R** rafters using **DR** brackets. Secure the **AR2IS** end panels to **S1** frames using tec screws. The end rafters need to be placed in position at the same time as the **AR2IS** end panels. Stick sealing strips to each rafter.

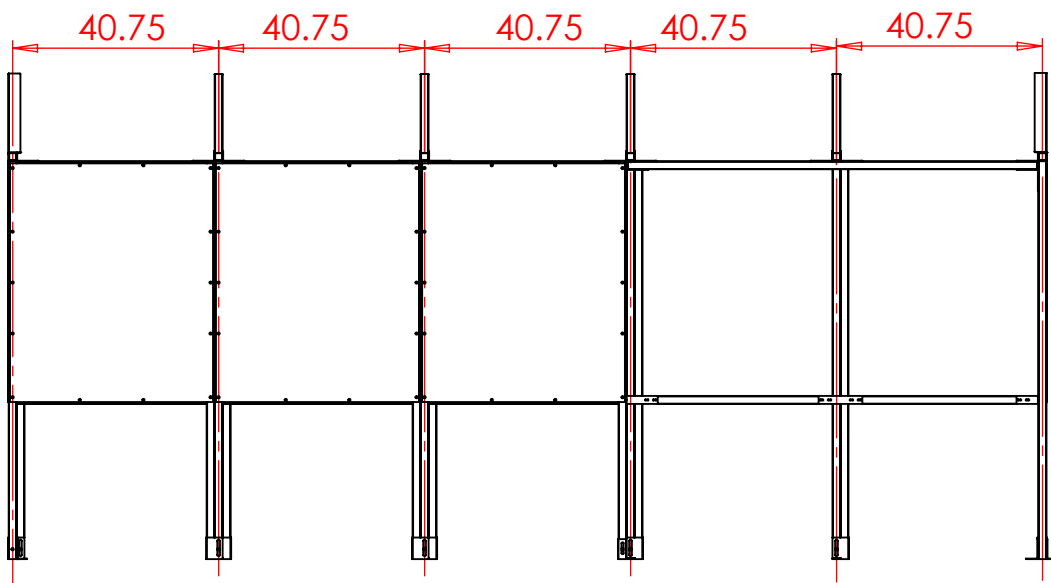
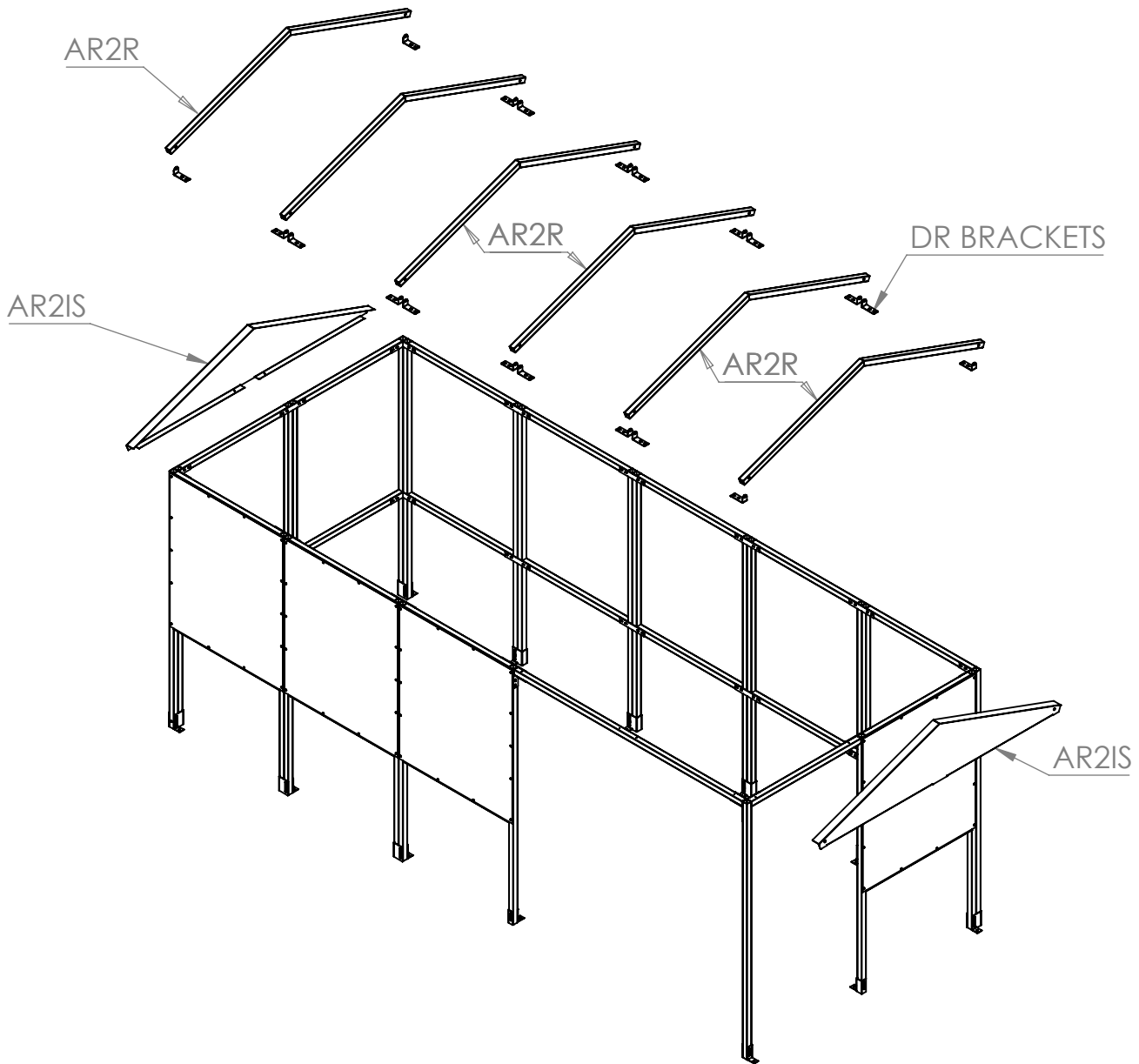

Step 4

Attach the **AR2CLTO** and **AR2CLTI** to the top of the rafters. The **AR2CLTO** are to be lined up near the end panels and the **AR2CLTI** have to be spaced equally along the centre. The **ARFSO** and **ARFSI** parts are to be attached to the lower part of the rafters as shown below. Once the shelter is in the final position and square, it can be secured to the ground using the **FT3** and **FT1** brackets.

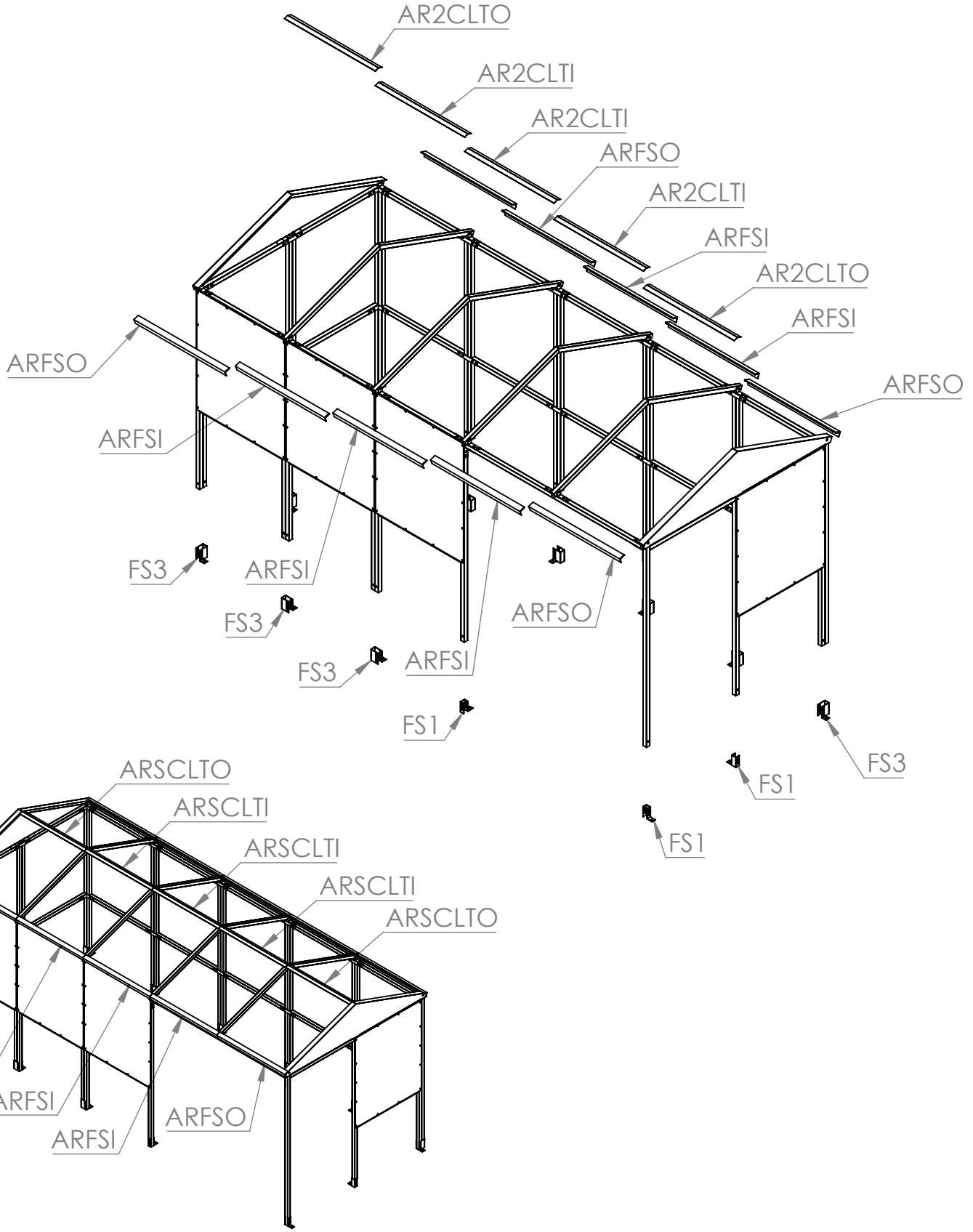

Step 5 Attach the **AR2POA** roof panels on the outer edges of the shelter nearest to the end panels and the **AR2PIA** panels need to be equally spaced along the centre. Cap off the top using **AR2CUTO** and **AR2CUTI** as shown below. use the **AR2TS** strips to cover the gaps between the panels.

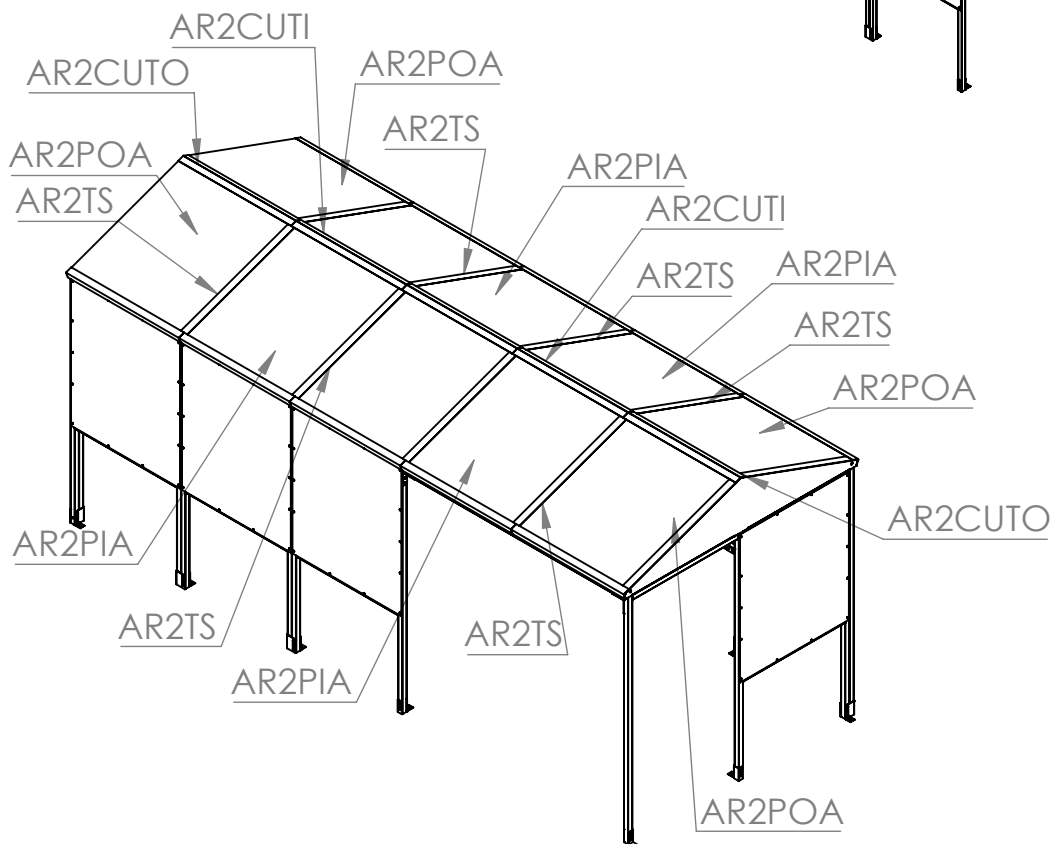
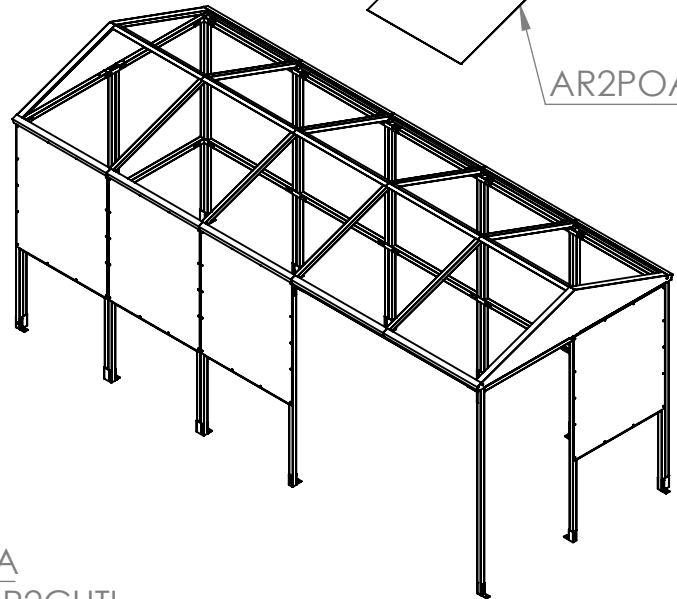
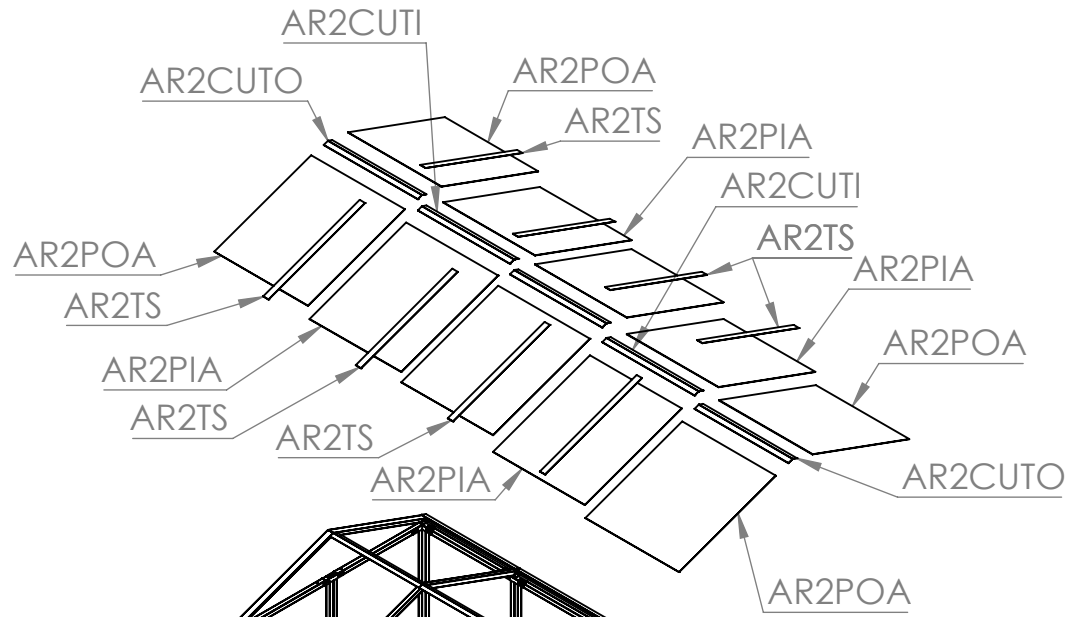

PLAN VIEW

OVERALL DIMENSIONS AND GROUND FIXING POSITIONS

Suggested size for concrete base: 200mm oversized on all 4 sides.

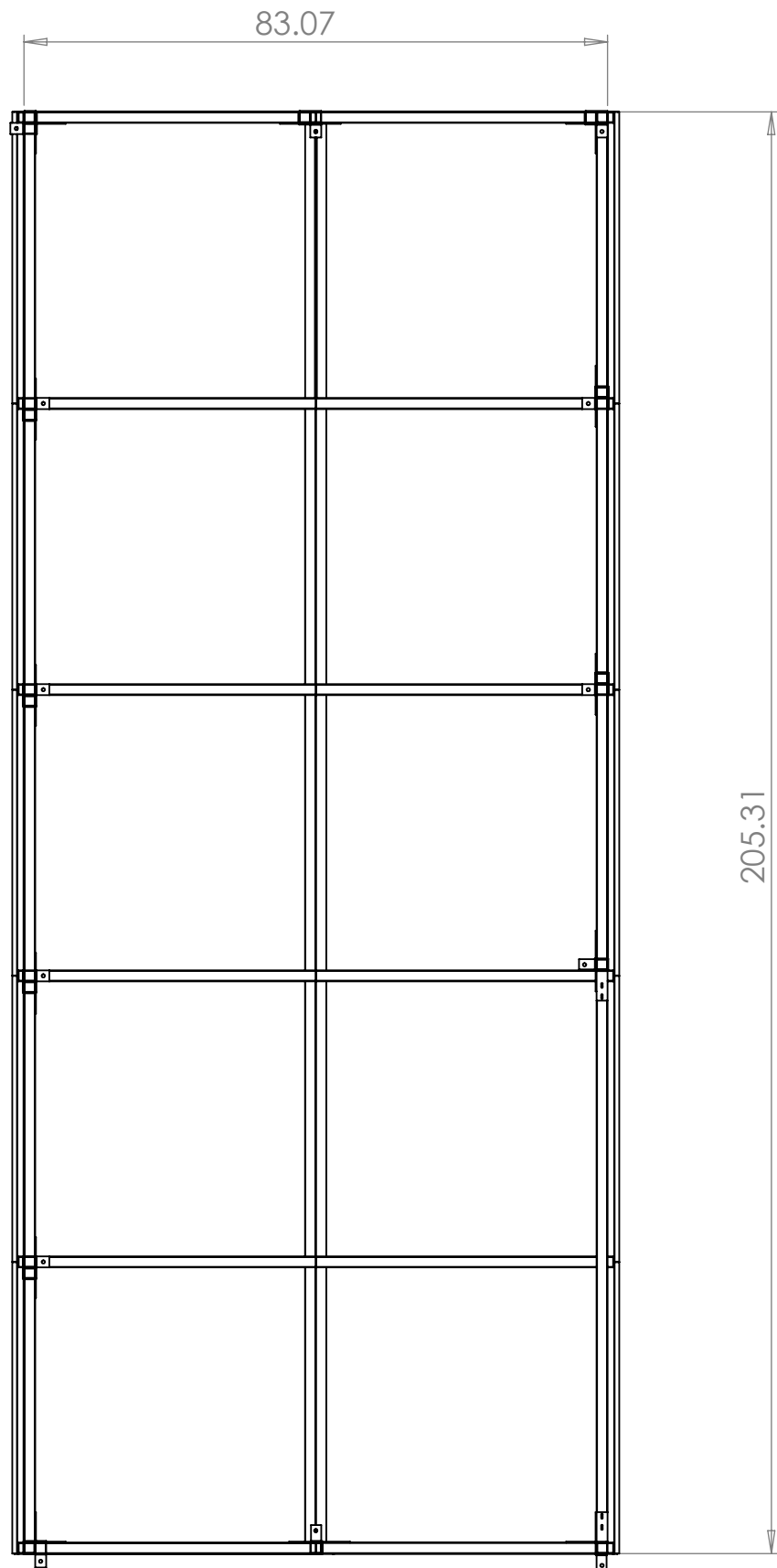

THANK YOU FOR PURCHASING THIS PRODUCT

MAINTENANCE:

To ensure your products give you many years of use we recommend that you:

- Clean panels regularly with soapy water
- Ensure all fittings are tight (for example after a big storm)
- Touch up any exposed metal should it get scratched

CONTACT DETAILS:

No Butts Bin Company, Inc.
16 Birch Lane, Madison, CT 06443

Email : Sales@nobutts.com

Web : www.nobutts.com

Tel : 1-888-662-8887

All Parts and Fixings checked by:	
Print Name:	Signature: