

Assembly Instructions



No Butts Bin Co.
Better Ash & Trash Solutions
Est. 1991

Email : Sales@nobutts.com
Web : www.nobutts.com
Tel : 1-888-662-8887

Shelter type: SR1562-F

SR1562-F-05-200219-USA

Exploded View of Shelter

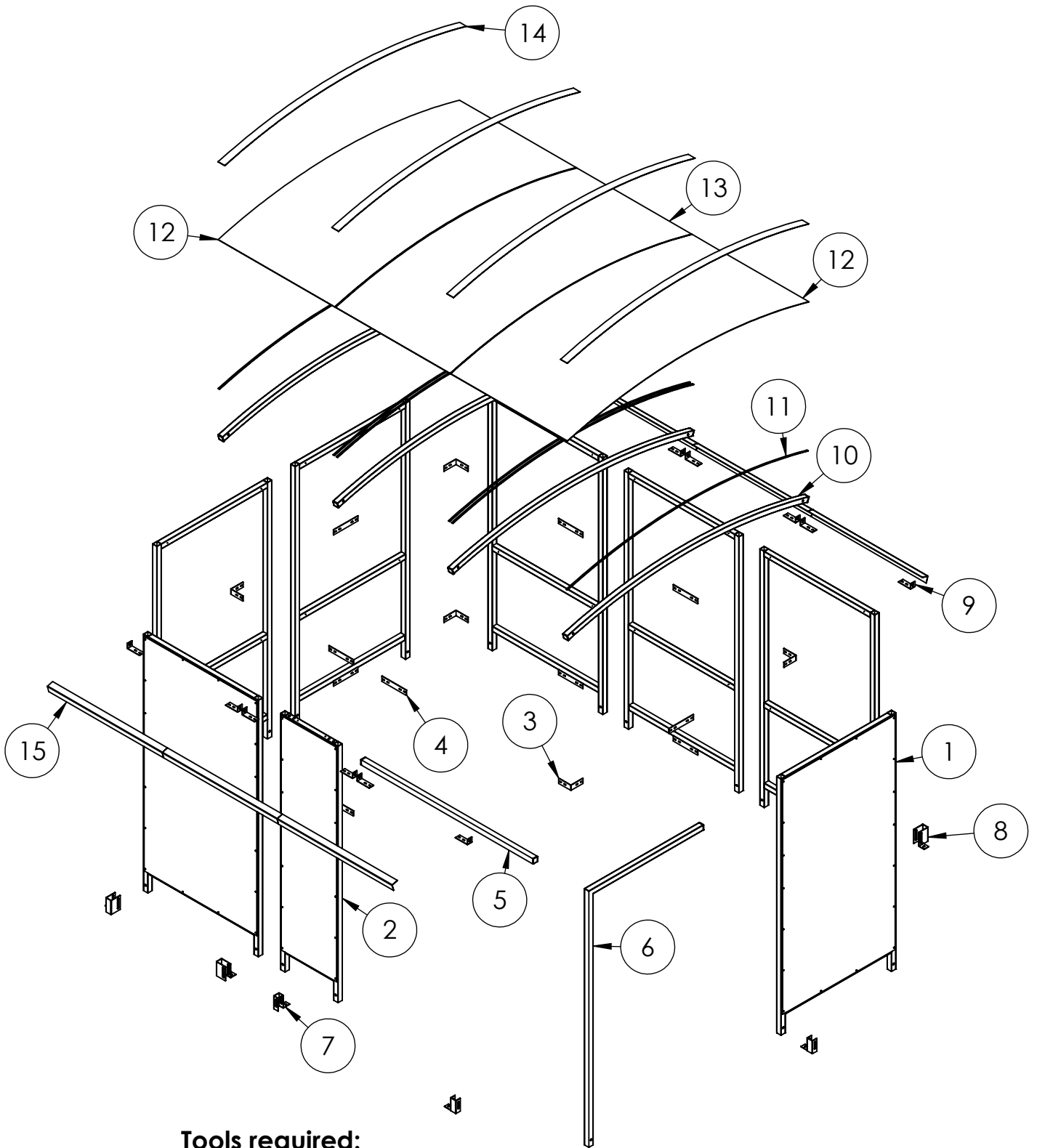

Tools required:



Drill/Screwdriver



Wrench



Mallet















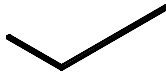

Torx bit

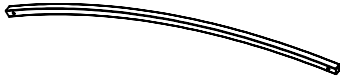

Hack saw

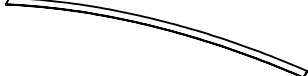
PARTS LIST AND FIXINGS

ITEM NO.	PART NO.	DESCRIPTION	DIMENSIONS (MM)	DIMENSIONS (INCH)	IMAGE	QTY.
1	S1C	Frame	2000x1035	78.74x40.75		7
2	S3C	Frame	2000x517	78.74x20.35		1
3	CB1	Bracket	110x110	4.33x4.33		7
4	JF1	Bracket		7.87x1.58		10
5	ST5	Roof Tie	1543x40x40	60.75x1.58x1.58		1
6	P1	Post	2000x1030	78.74x40.55		1
7	FT1	Foot Bracket	109x100x40	4.29x3.94x1.58		3
8	FT3	Foot Bracket	109x100x80	4.29x3.94x3.15		7
9	RB1	Bracket	110x42x40	4.33x1.81		12
10	R2	Rafter	2200x40x40	86.61x1.58x1.58		4
11	SS	Sealing Strip	Trim To 2200	Trim To 86.6		3 ROLLS
12	ACE2	Roof Panel	2210 x 1050	87 x 41.34		2
13	ACC2	Roof Panel	2210 x 1030	87 x 40.55		1
14	RC2	Roof Strip	2180	85.83		4
15	A2	Roof Angle	1035 x 50 x 50	40.55 x 1.97 x 1.97		6
16	EC40	Plastic End Cap	40x40	1.58x1.58		20

Fittings	Bolt set M10			T25		BTANCM12100	
	M10 x 60mm	Nut	Washer	25 mm Tech screw	Black Caps	M10/12 x 100 mm Concrete Bolt	
Pack C+D	33	33	66	202	66	11	
Required	28	28	56	104	56	8	
Image							

Step 1 Assemble **S1C** frames to make up the main structure using **CB1** brackets for the Corners and **JF1** brackets for the straight joints.

Please note 25mm Tec Screws are for roof panels only

BLUE DIMENSIONS - MM
GREEN DIMENSIONS - INCH

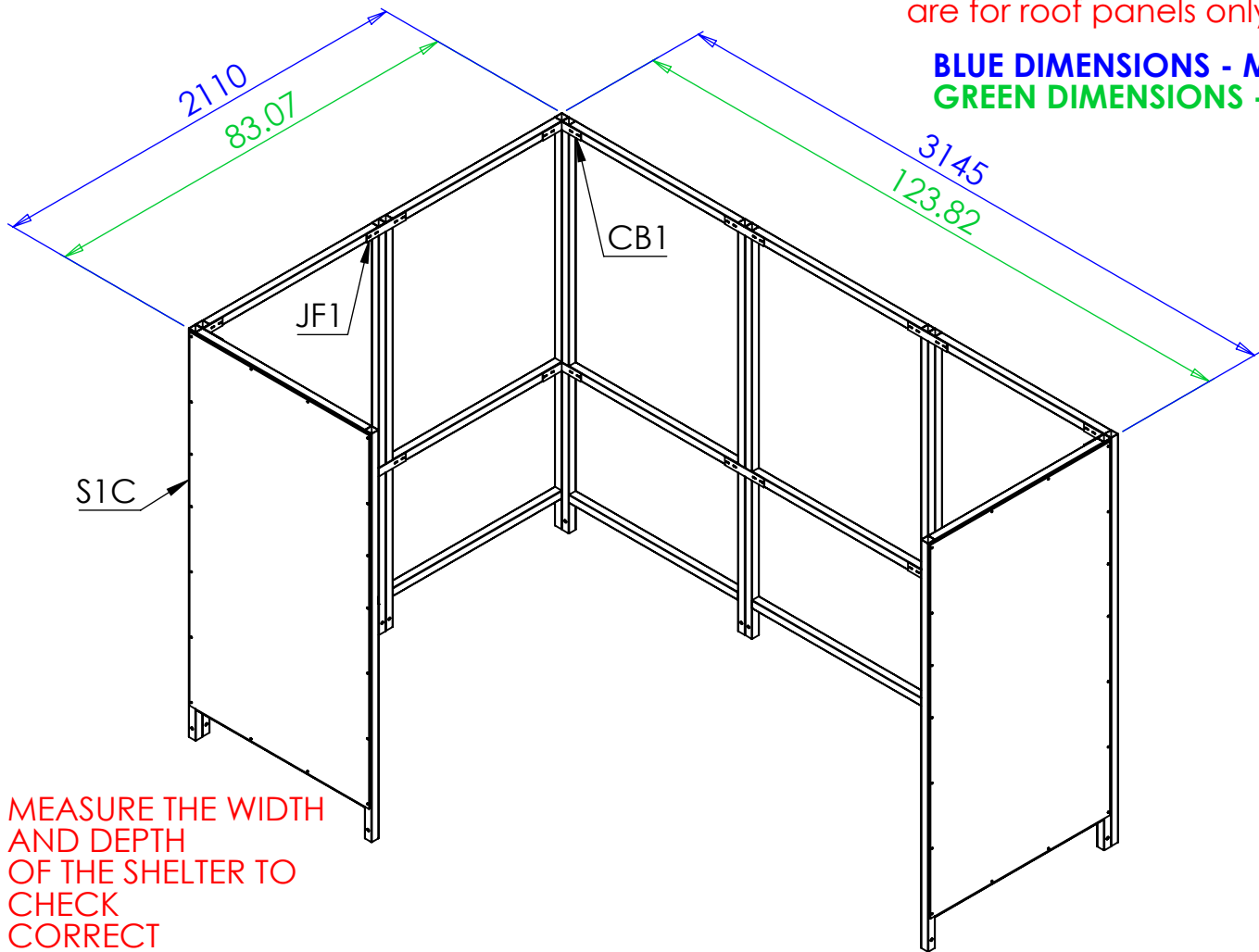

MEASURE THE WIDTH AND DEPTH OF THE SHELTER TO CHECK CORRECT ALIGNMENT.

Ensure correct corner alignment

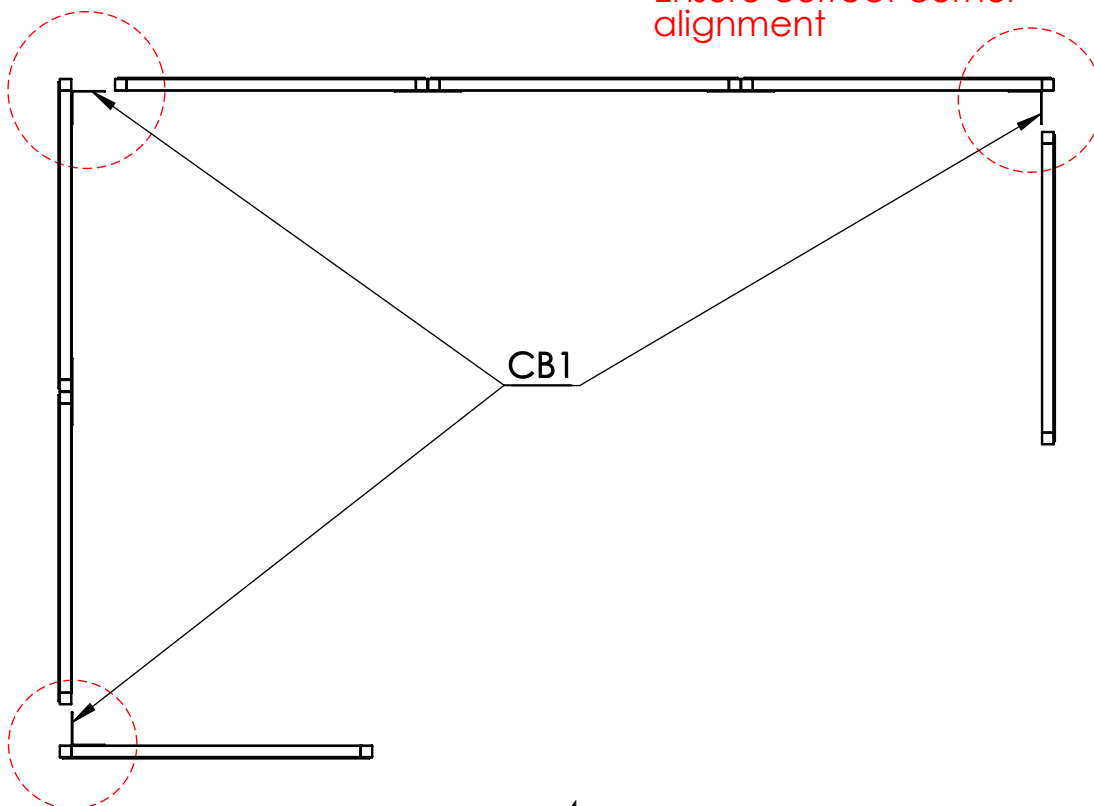

Step 2 Attach **P1** post using a **JF1** bracket then use two **JF1** brackets to attach **S3C** frame. The **ST5** tie bar is mounted using a **CB1** and a **JF1** bracket. Make sure the structure is square then move the shelter to its final location before using the **FT1** foot brackets to secure it to the ground.

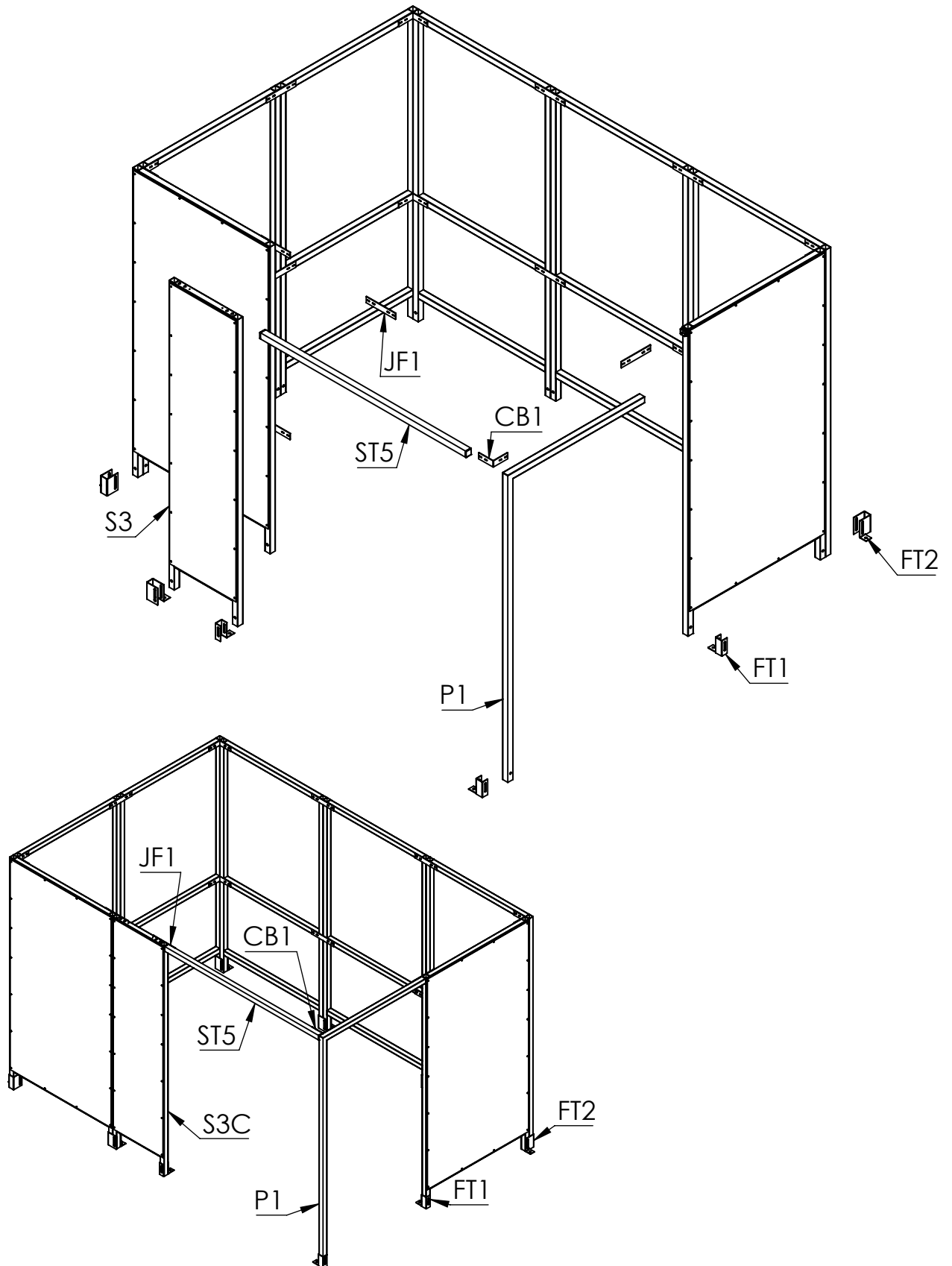

Step 3 Attach **R2** rafters using **RB1** brackets.

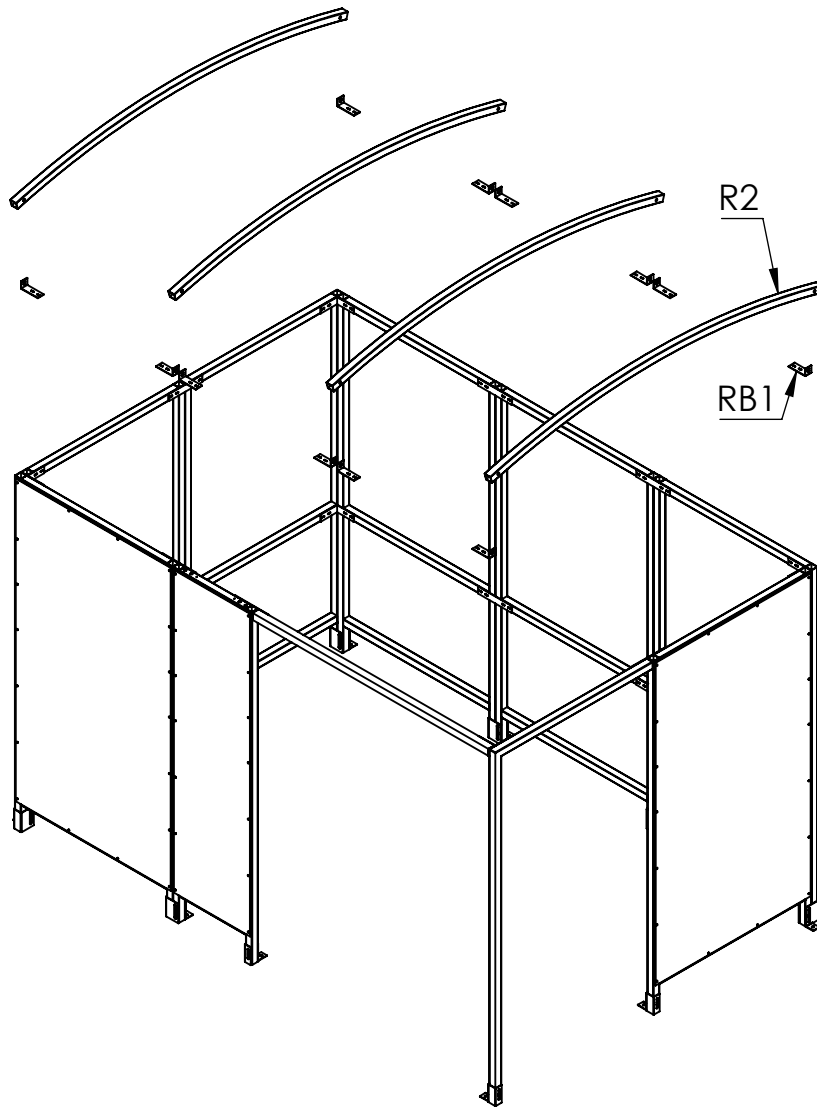

ENSURE
CORRECT
ALIGNMENT
OF RAFTERS

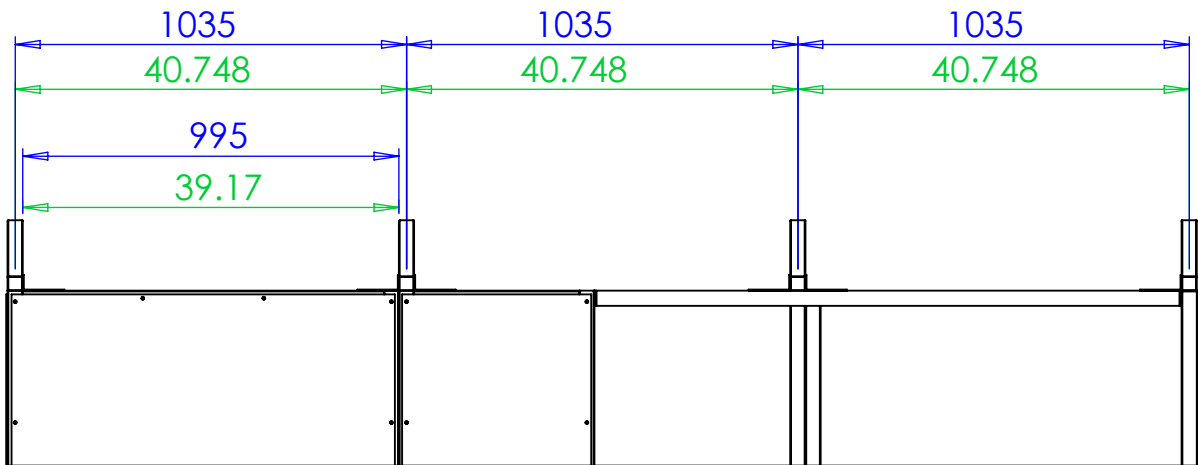

SCALE - 1:20

Step 4 Stick sealing strips (**SS**) to the rafters. Align the **ACE2** roof panels with the outer roof rafters and equally space the **ACC2** panel in the middle.

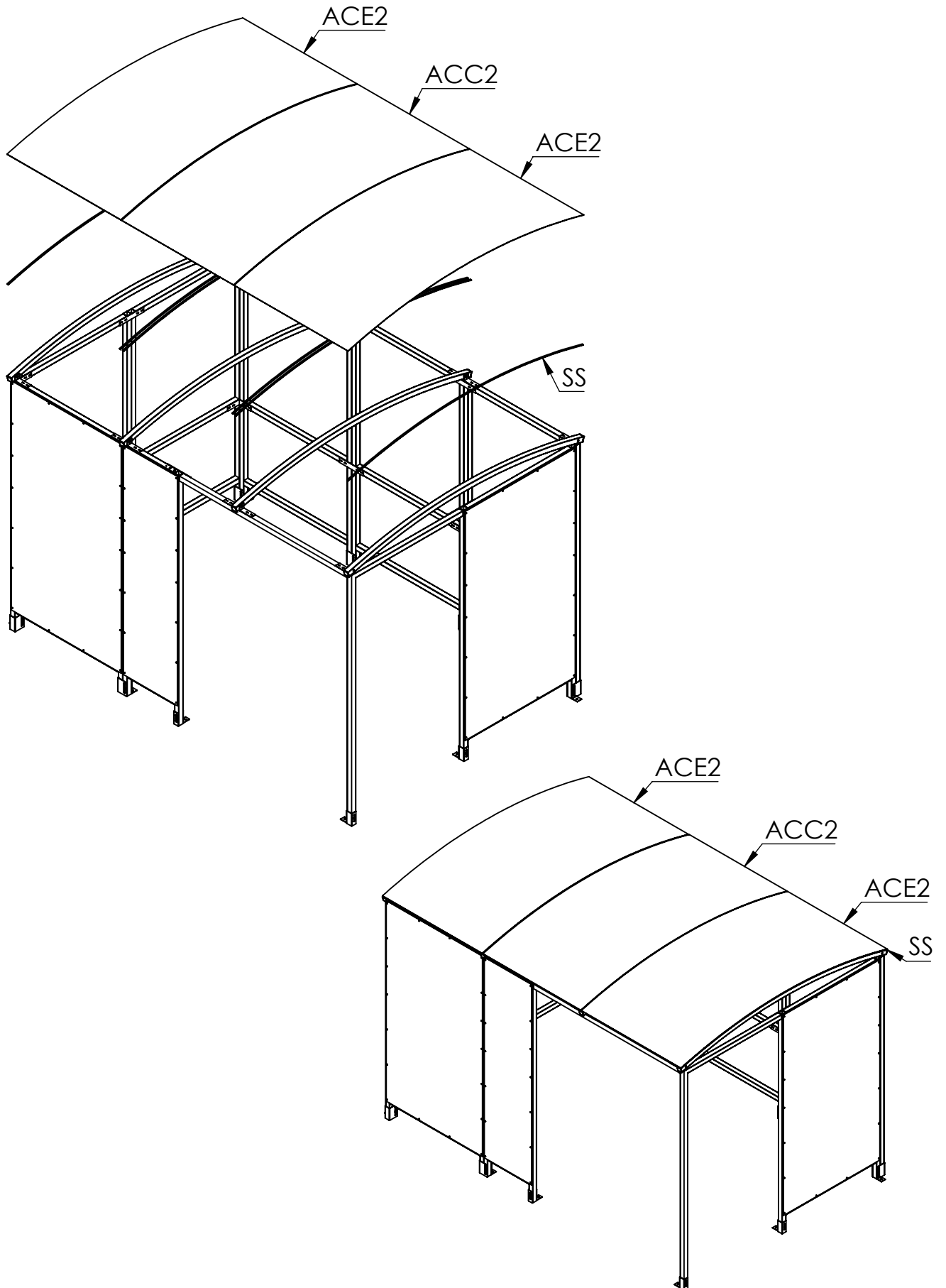

Step 5 Screw down the **RC2** directly into the rafter strips as shown below, using **25mm Tech screws**. Screw the **A2 Angle** onto the edges of the roof as shown below.

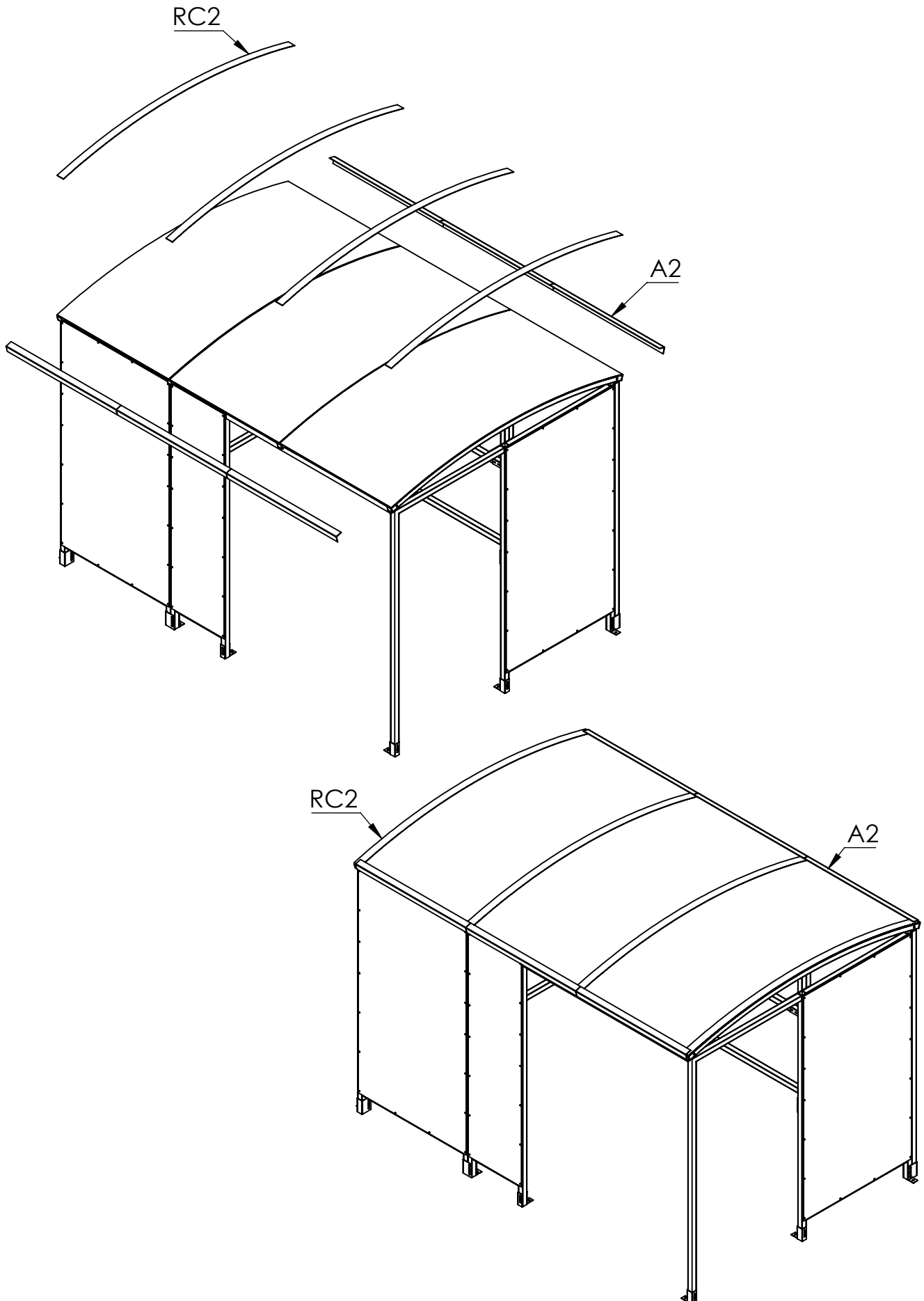

PLAN VIEW

OVERALL DIMENSIONS AND GROUND FIXING POSITIONS

Suggested size for concrete base: 200mm OR 7.87in oversized on all 4 sides.

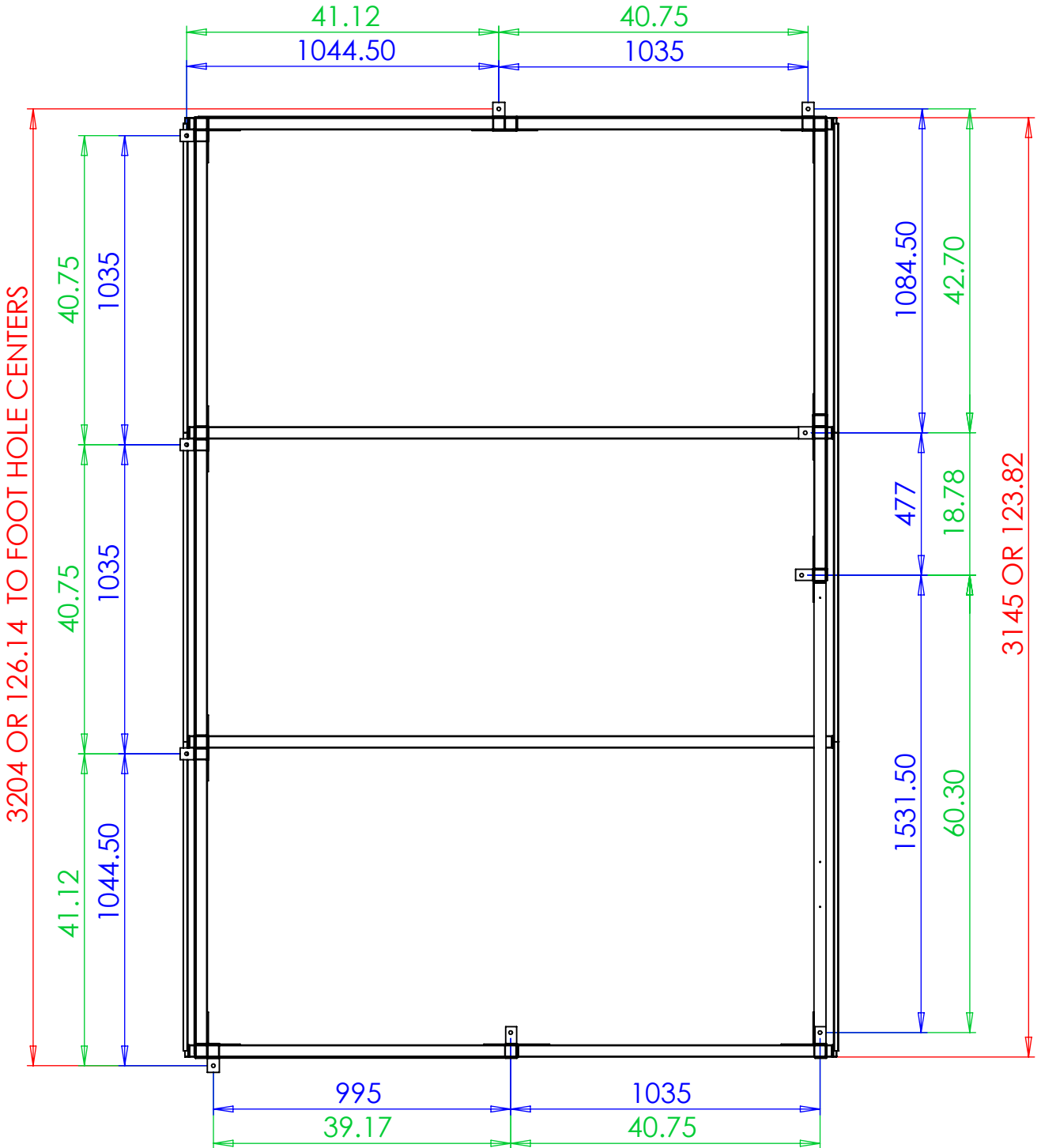

Notes:

Notes:

THANK YOU FOR PURCHASING THIS PRODUCT

MAINTENANCE:

To ensure your products give you many years of use we recommend that you:

- Clean panels regularly with soapy water
- Ensure all fittings are tight (for example after a big storm)
- Touch up any exposed metal should it get scratched

CONTACT DETAILS:

Email : Sales@nobutts.com

Web : www.nobutts.com

Tel : 1-888-662-8887

No Butts Bin Company, Inc. 16 Birch Lane, Madison, CT 06443

All Parts and Fixings checked by:	
Print Name:	Signature: